

# Grease Steel Dust Meter SDM-72

---

## Instruction Manual

---

- Keep this manual for easy reference.
- Carefully read this manual prior to use.



**NEW COSMOS ELECTRIC CO., LTD.**

# Table of Contents

1. Introduction .....	1
2. Features of this Product .....	1
3. Safety Precautions.....	1
Symbols Used in this Manual.....	1
Safety Precautions .....	2
4. Package Contents .....	3
5. Consumables.....	3
6. Component Names and Functions .....	4
7. Operation .....	5
7-1. Battery Installation .....	5
7-2. Battery Check .....	5
7-3. Taking Measurements.....	6
7-4. Grease Sampling .....	7
7-5. Sample Tube Filling .....	7
8. Error Codes .....	8
9. Troubleshooting .....	9
10. Warranty .....	10
11. Maintenance .....	10
12. Specifications.....	11
Appendix: Measuring Principle .....	i
A1. Magnetic Balance-Type Electromagnetic Induction Method .....	i
A2. Measurable Metals .....	ii
A3. Usage .....	iii
(1) Major Applications.....	iii
(2) Correlation between Steel Dust Concentration and Bearing Wear Status.....	iv
(3) Criteria (Reference) .....	iv
(4) Measurement Cycle.....	v
(5) Trend Management and Simplified Diagnosis of Bearing Wear.....	vi
(6) Iron Particle Diameter and Detection Range Comparison among Measuring Methods .....	vii
(7) Comparison between SDM-Measured Values and ICP-Analyzed Values .....	viii

# 1. Introduction

Thank you for purchasing the SDM-72 grease steel dust meter.

Prior to use, please carefully read this manual to ensure correct use. This product is suitable for preventive maintenance of bearings and gears of rotating machinery such as motors, pumps, industrial robots, vessel engines, wind turbines, and elevators.

# 2. Features of this Product

The grease steel dust meter is a portable analyzer designed to measure the steel dust concentration in lubricating grease on-site. It is useful when checking the wear condition of bearings and gears.



It is also very easy to use. Simply sample a small amount of grease waste discharged from the machinery at the time of grease lubrication, and set it in the meter.

- **Highly sensitive**  
The meter is able to identify the initial bearing wear because it employs a magnetic balance-type electromagnetic induction method as its measuring principle.
- **High precision**  
The meter is able to find an abnormality in the ultra-slow speed rotation, which is difficult to detect by the vibration analysis technique.
- **User-friendly**  
Just fill a sample tube with the grease specimen and insert it into the meter. Within a few seconds the meter gives you a readout of the ferromagnetic particles in the grease as a percentage of the total weight.
- **Compact and portable**  
There is no longer any need to send your sample to a laboratory for analysis, making on-site measurement possible.

# 3. Safety Precautions

## Symbols Used in this Manual

This manual uses Warning, Caution and Note symbols to draw attention to procedures, materials, methods, and processes, which require particular attention.

 <b>WARNING</b>	Indicates a potentially hazardous situation that may result in death or serious injury.
 <b>CAUTION</b>	Indicates a hazardous situation that may result in minor injury or property damage.
<b>NOTE</b>	Provides information on product handling.

## Safety Precautions

To ensure safe operation, follow the precautions below.

### CAUTION

- This product is not explosion-proof and should not be used in explosive atmospheres.
- Avoid any strong mechanical shock or impact to the product as a result of dropping or bumping against a surface. Failure to do so may impair the performance of the product.
- Do not leave the product in a high-temperature/humidity environment for an extended period of time. Doing so may cause device failure.
- Do not expose the product to rapid temperature/humidity changes. Doing so may cause device failure.
- The product is not drip-proof. Keep the product away from water. Failure to do so may cause device failure.
- If this product is to be left unused for an extended period of time, remove the batteries from the unit. Failure to do so may cause device failure.
- This product is a precision instrument. Do not disassemble, modify, or alter the structure of the product or its electrical circuits. Doing so may compromise the performance of the product.
- This product employs the electromagnetic induction method as its measuring principle, and should not be used in the vicinity of devices emitting a strong electromagnetic wave. Electromagnetic waves may cause a drift in the reading.
- Keep the product away from wireless devices (e.g., walkie-talkies, cellphones) while in use.
- The sampling port is equipped with an optical sensor. Keep the sampling port and optical sensor clean, as correct measurement is not possible if they are contaminated with iron particles, etc. If contaminated, wipe them with a cotton swab or cloth.
- If the product is dirty, wipe it with a soft, dry cloth. Do not use alcohol, detergent, benzene, thinner, or a wet cloth.

## 4. Package Contents

A standard package consists of the following items. If any items are missing or damaged, please contact New Cosmos or its authorized representative for replacement.

Item	Model/Part No.	Quantity
SDM-72 grease steel dust meter	SDM-72	1
Spatula		1
Sample tube, with cap	SMC-01G	1 box (10 pcs)
AA battery		4
Carry case, with shoulder strap		1
Instruction manual (this document)		1
Inspection certificate		1

## 5. Consumables (sold separately)

Item	Model/Part No.
Sample tube, with cap (10 pcs)	SMC-01G

## 6. Component Names and Functions

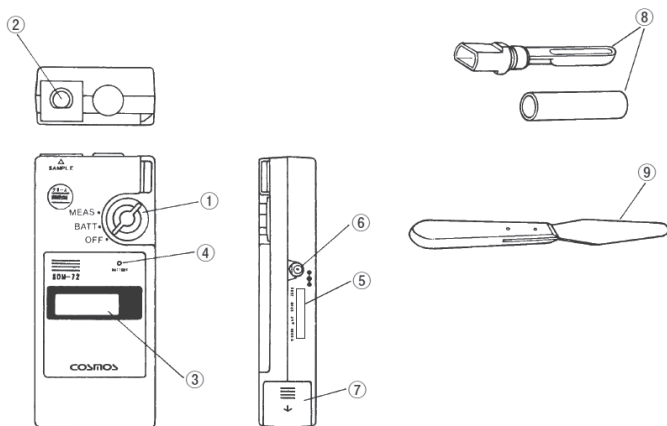

Figure 1. Exterior Appearance

Item	Component	Function and Description
①	Selector switch	<ul style="list-style-type: none"> <li>Set the switch to <b>MEAS</b> to enter measurement mode; set to <b>MEAS</b> before inserting the sample tube into the meter</li> <li>Set the switch to <b>BATT</b> to check the battery voltage</li> <li>Set the switch to <b>OFF</b> to turn off the unit</li> </ul>
②	Sampling port	Insert a sample tube here for measurement
③	LCD	Displays the steel dust concentration value, battery voltage, or error code
④	Battery alarm LED	Turns red when the battery voltage decreases and reaches the discharge-cutoff voltage (3.6 V); notifies users to replace the batteries; starts blinking when the battery voltage decreases to 3.2 V or lower
⑤	Calibration date label	Indicates the calibration date; do not remove the label
⑥	DC jack	(For use in Japan only. Used to connect the AC adaptor.)
⑦	Battery compartment	Houses four AA batteries
⑧	Sample tube	0.8 ml sample container with cap
⑨	Spatula	Used to collect grease sample

## 7. Operation

### 7-1. Battery Installation

Open the battery lid. Insert four AA batteries in the correct orientation (polarity +/-).

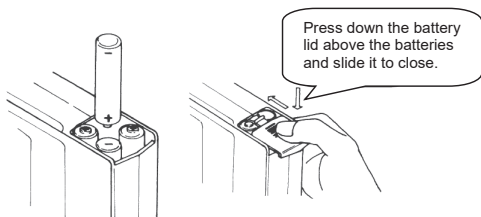

Figure 2. Battery Installation

### 7-2. Battery Check

Set the selector switch to **BATT**. “— — — —” will be displayed on the LCD for a few seconds, and then it will be replaced by the battery voltage.

b 5. 6

Battery voltage is 5.6 V.

b 3. 6

When the battery voltage exceeds 3.6 V, the unit is ready for use. When the voltage decreases to 3.6 V or lower, the battery alarm LED will turn red, indicating that the batteries need to be replaced with new ones.

b 3. 2

When the battery voltage decreases to 3.2 V or lower, the battery alarm LED will start blinking and the unit will start beeping indicating that the batteries need to be immediately replaced with new ones. If you continue to use the unit without battery replacement, **P. OFF** (power off) will be displayed, then the unit will be shut down.



#### CAUTION

- Accurate measurement is not possible if the battery alarm LED is lit or blinks. Replace the batteries with new ones.
- Replace all the four batteries at the same time.

#### NOTE

If the battery voltage decreases to 3.6 V or lower while the selector switch is in the **MEAS** position, the battery alarm LED will turn red. If the battery voltage decreases to 3.2 V or lower while the selector switch is in the **MEAS** position, the battery alarm LED will start blinking and the unit will start beeping in the same way as when the switch is in the **BATT** position.

### 7-3. Taking Measurements

- (1) Set the selector switch to **MEAS** to enter measurement mode.
- (2) Ensure that **0.000** appears on the LCD with no sample tube inserted.
- (3) Completely insert the sample tube filled with the grease sample into the sampling port.

Note: A sample tube has a certain orientation. Insert the sample tube into the sampling port with its flat surface facing forward. For the grease sampling method, refer to page 7.

- (4) When the measurement is complete, the unit will give a short beep. The reading is displayed on the LCD. Record the reading.
- (5) Remove the sample tube from the port. The reading will return to **0.000**.
- (6) Return the selector switch to **OFF** to end the measurement.

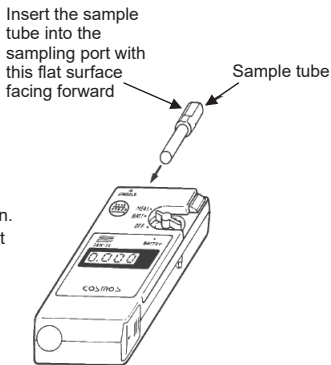

Figure 3. Sample Tube Insertion

#### CAUTION

- Accurate measurement is not possible if an empty sample tube is inserted.
- Avoid causing any impact and slowly insert the sample tube into the sampling port. Failure to do so may cause the reading to drift. Inserting the sample tube too slowly may also cause the reading to drift. If a drift occurs, remove the sample tube from the sampling port, and then reinsert it.
- Once you insert the sample tube in the sampling port, do not move it until the unit gives a short beep indicating measurement completion. Impact during measurement may cause a drift in the reading.
- During measurement, when holding a sample tube in your fingers, hold its grip so as not to warm the sample. Failure to do so may cause a drift in the reading because of a transfer of body heat.
- If the temperature of the sampled grease is high, allow it to cool down to normal temperature before measurement.



## 7-4. Grease Sampling

It is necessary to take a grease sample expelled from the rotating machinery at the time of grease lubrication, and to fill the sample tube with it using the spatula provided. When lubricating the rotating machinery with fresh grease, layers of discolored old grease and fresh grease are expelled together. Take a grease sample from the most discolored layer.

## 7-5. Sample Tube Filling

- (1) Fill the sample tube's measuring groove with the grease on the spatula. Ensure that a slightly excessive amount is filled and no air is present.
- (2) Scrape off the excessive grease with the spatula to obtain a volume of 0.8 ml of the specimen.
- (3) Wipe off any excessive grease remaining on the body of the sample tube with a tissue or soft cloth. Attach the cap to the tube.

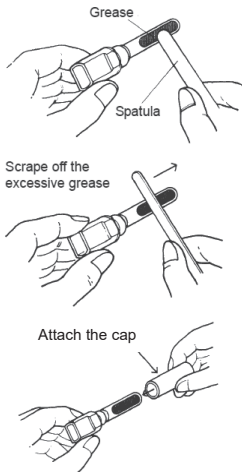

Figure 4. Sample Tube Filling



### CAUTION

- While sampling, ensure that no dust, dirt, or rust enters the sample from the surrounding areas.
- The reading may vary according to the sampling location, because steel dusts do not spread evenly in waste grease. Take a few samples in a few different locations to obtain a maximum or majority value. Take a grease sample from the most discolored layer.
- Refer to the Appendix (page iv) for the correlation between the steel dust concentration and the bearing wear status.

## 8. Error Codes

In case of an error, the corresponding error code is displayed on the LCD. Take the necessary action according to the displayed error code, as well as measures suggested in the next section, "Troubleshooting".

**Table 1. Error Code Table**

Error code on screen	Cause	Action
----- (Blinking)	Cannot start zero adjustment because the unit was turned on while the grease sample was inserted	Remove the sample tube from the unit and wait until "0.000" is displayed before using again
	Measurement error Grease sample was removed from the unit before the completion of measurement	Remove the sample tube from the unit and reinsert it, then measure again
P. OFF	Unit was forcedly turned off because the battery voltage is too low	Set the selector switch to <b>OFF</b> , and then set it to <b>BATT</b> or <b>MEAS</b>
Err. E	Device error Non-volatile memory write error	Set the selector switch to <b>OFF</b> , and then set it to <b>BATT</b> or <b>MEAS</b> . If the error code is still displayed, repair is necessary
Err. r	Device error Non-volatile memory read error	
Err. S	Device error Non-volatile memory check sum error	
Err. A	Device error No response from the AD converter	
Err. F	Device error Abnormal sensor output	

## 9. Troubleshooting

Before contacting us for service repairs, please perform basic troubleshooting using the table below.

**Table 2. Troubleshooting**

Symptom	Cause	Action
Setting the selector switch to <b>BATT</b> or <b>MEAS</b> does not turn on the LCD	• Battery depleted	• Replace the batteries with new ones (page 5)
	• Incorrect battery orientation	• Remove and reinsert batteries in the correct orientation (page 5)
Battery alarm LED is lit or blinking	• Battery is low or depleted	• Replace the batteries with new ones (page 5)
Battery alarm LED is lit or blinking even after new batteries are installed	• Incorrect battery orientation	• Remove and reinsert batteries in the correct orientation (page 5)
On-screen reading is unstable during measurement	• Grease sample is too hot to measure	• Allow the sample to cool down before measuring (page 6)
	• Sample tube is warmed by fingers	• Hold the sample tube by its grip during measurement (page 6)
“— — — —” blinks on the LCD	• Unit was turned on while grease sample (sample tube) was inserted	• Remove the sample tube from the unit and wait until “0.000” is displayed before using again
“0.000” is not displayed or “— — — —” blinks on the LCD even after grease sample (sample tube) is removed	• Optical sensor at the sampling port is dirty	• Wipe the optical sensor with a cotton swab or cloth to remove dirt
Reading does not change even when grease sample (sample tube) is inserted		
Reading does not become “0.000” even when there is no grease sample in the sample tube	• Reading has been calibrated to “0.000” by using fresh grease. It is not possible to check “0.000” by using air	• Insert a sample tube filled with fresh grease, then check that the reading becomes “0.000”
Error code is displayed	Refer to the Error Code Table on page 8	

## 10. Warranty

The warranty period is one (1) year from the date of purchase.

You are entitled to limited warranty if the product malfunctions due to a manufacturing defect during normal use, in accordance with the instruction manual, specifications and labels.

### Warranty Scope

If the product fails or is found to be damaged due to a manufacturing defect during the warranty period, and used in accordance with the instruction manual and specifications, we will provide a free replacement and repair services. This warranty covers the New Cosmos product/parts only and not third-party product/parts.

### Warranty Exclusions

The following will be repaired at the cost of customer even during the warranty period:

- (1) Failures and damages incurred by incorrect use, deliberate acts or negligence on the part of the user
- (2) Failures and damages caused by disasters such as earthquakes, storms and floods, lightning, extreme climate, abnormal power supply voltages, excessive electromagnetic interferences, or other acts of God
- (3) Failures and damages resulting from repair and/or modification by non-New Cosmos certified technicians
- (4) Consumables and failures and damages resulting from improper consumable replacement
- (5) Other failures and damages not attributable to the manufacturer

## 11. Maintenance

In order to ensure the accurate operation of this product, it is vital to perform periodic maintenance and inspection. It is highly recommended that a maintenance contract with a New Cosmos local representative be made for annual maintenance and inspections.

## 12. Specifications

Model	SDM-72
Measuring principle	Magnetic balance-type electromagnetic induction method
Target	Steel dust concentration in grease
Measurement range	0 to 5.000 %Wt
Concentration display	Four digit LCD
Resolution	0.001 %Wt
Accuracy	± (10 %reading + 10 digits) Compared with the value measured by ICP analysis on the company standard grease sample
Zero adjustment	Automatic adjustment
Sample volume	0.8 ml
Power supply	AA batteries x 4 pcs
Continuous operating time	Approx. 30 hours
Operating temperature	0 to 40 °C
Dimensions	Approx. W84 × H190 × D40 mm
Mass	Approx. 500 g (including batteries)
Compliance	EMC directive ( 2014/30/EU/SI 2016 No.1091 ) and RoHS directive ( 2011/65/EU+(EU)2015/863/SI 2012 No.3032 )

- Above specifications may be subject to change without notice for product improvement.
- %Wt = weight ratio%

## Appendix: Measuring Principle

### A1. Magnetic Balance-Type Electromagnetic Induction Method

This product employs a magnetic balance-type electromagnetic induction method, as illustrated in the Figure A1 below, as its measuring principle.

This is a magnetic circuit sensor formed by placing a detection coil between two exciter coils, so that magnetic fields generated by the exciter coils are canceled by each other, resulting in no magnetic field around the detection coil.

The detection coil does not normally generate an induction voltage. However, when a grease sample containing iron particles is inserted into one of the exciter coils, the magnetic permeability will change, causing a magnetic imbalance, which will then cause the detection coil to generate an induction voltage. The iron particle concentration in the grease can be measured by measuring the induction voltage.

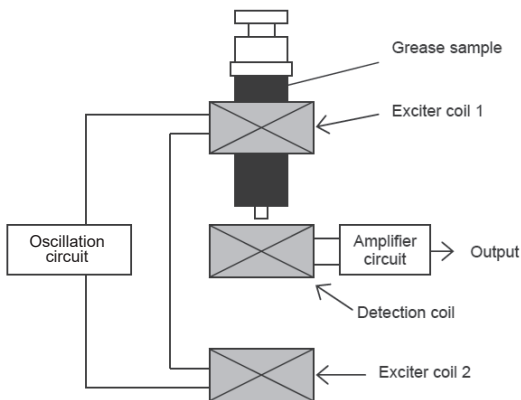

Figure A1. Magnetic Balance-Type Electromagnetic Induction Method

## A2. Measurable Metals

**Table A1. Measureable and Non-Measurable Metals**

Metal	Magnetic property	Measurable	Remarks
Iron, nickel, cobalt	Ferromagnetic	✓	
Aluminum, chrome, manganese, titan, stainless steel (SUS-304, SUS-316)	Paramagnetic	X	
Copper, silver, lead, zinc, tin	Diamagnetic	X	
Sodium, calcium, lithium, molybdenum	Paramagnetic	X	*1
Iron oxide ( $\alpha$ -Fe <sub>2</sub> O <sub>3</sub> ), iron dust (hydroxide iron)	Paramagnetic	X	*2
Iron oxide ( $\gamma$ -Fe <sub>2</sub> O <sub>3</sub> , Fe <sub>3</sub> O <sub>4</sub> )	Ferromagnetic	✓	

\*1. These are raw materials used to make oil thickeners. This product has no sensitivity to them; therefore, they have no effect on the reading of the product.

\*2. There are several isomers of iron oxide. Some of them can be measured using this product while others cannot, as shown in the table above. If the specimen contains red rust or if it is measured in an environment where steel dust may easily oxidize, the reading may be especially lower than the actual concentration value.

## A3. Usage

### (1) Major Applications

- Trend management and simplified diagnosis of wear status of grease-lubricated bearings and gears

This product can be used to check the lubrication of low to high speed rotating machinery. It is especially suitable when used as a simplified diagnosis of wear status of low speed rotary bears and gears, which is otherwise difficult to diagnose with the vibration analysis technique. It is possible to improve the diagnosis accuracy of middle and high speed rotating machinery by using this product along with a vibration meter.

- Preliminary diagnosis for SOAP method, ferrography method, etc.

This product's usage leads to maintenance cost reduction.



Pumps & Motors



Agitators



Fan-blower · Compressor



Cooling tower · Air fin cooler



Mixer · Kneader



Rotary drier



Paper-marking machinery



Mill · Crusher · Refiner



Metal rolling machinery



Conveyor



Crane · Hoist · Lift



Civil engineering machinery



Rolling stock ·  
Transportation



Elevator



Escalator ·  
Moving sidewalk



Parking tower

**Figure A2. Typical Applications**



## (2) Correlation between Steel Dust Concentration and Bearing Wear Status

Table A2 shows the inspection result (correlation between the steel dust concentration and the bearing wear status) of disassembling and checking the bearings of various rotating machinery, e.g., motors, pumps, and blowers.

**Table A2. Correlation between Steel Dust Concentrations and Bearing Wear Status**

Iron concentration (%Wt)	Number of bearings and their wear status
0.3–1.0	◆◆◆
0.1–0.3	●●▲▲▲▲
0.05–0.1	●●●●●
0.03–0.05	○○
0.01–0.03	○○○○○○○○○○
0–0.01	○○○○○○○○○○○○
Total number of bearings inspected: 36 pieces ◆: Severe wear (continuous flaking on inner ring, outer ring, and balls) ▲: Medium wear (partial flaking on inner ring, outer ring, and balls) ●: Slight wear (discoloration and small fretting on inner and outer rings) ○: Normal	

## (3) Criteria (Reference)

The criteria for steel dust concentration in the grease sample are given in Table A3. They are set to be relatively strict so as to detect an abnormal trend of initial wear at an early stage to ensure that you take appropriate and timely corrective steps that ensure long life for your machinery.

The machinery type and condition of use vary greatly. Hence, these criteria are not suitable for all types of machinery. It is recommended that you establish suitable operating criteria through the data accumulation and trend monitoring of the steel dust concentration tendencies of your machinery.

**Table A3. Typical Criteria of Steel Dust Concentration in Grease**

Criteria	Judgement	Action
Less than 0.05%	Normal	Fill the machinery with fresh grease and monitor the steel dust concentration trend at a normal frequency
0.05–0.1%	Of Caution	Fill the machinery with fresh grease immediately, and then measure the concentration again after one month
Greater than 0.1%	Abnormal	Measure the concentration at shorter intervals; perform a thorough examination; take necessary corrective action (e.g., improvement of lubrication)

#### (4) Measurement Cycle

To measure the steel dust concentration in grease, it is necessary to take a sample of the grease waste expelled from the rotating machinery. Therefore, performing a measurement when lubricating the machinery with fresh grease as a part of periodical maintenance is efficient. The lubrication cycle should be determined upon considering the type, specifications, and operating conditions of the machinery. The typical measurement cycles are given in Table A4 as reference.

If an abnormal trend is detected in the steel dust concentration measurement, shorten the measurement cycle depending on the abnormality level. Lubricating at shorter intervals helps slow the progress of wear, which will then prolong the life of the machinery.

**Table A4. Typical Measurement Cycle**

Equipment	Frequency
Low speed rotating machinery used at normal temperatures	Every 3 to 6 months
Medium and high speed rotating machinery used at normal temperatures	
Low speed rotating machinery used at high temperatures	Every 1 to 4 months

## (5) Trend Management and Simplified Diagnosis of Bearing Wear

A simplified diagnosis of bearing wear by a single steel dust concentration measurement is possible, but it is important to perform trend analyses of the wear through periodical measurements.

During normal conditions, the steel dust concentration in the grease changes within the very low concentration zone. As bearing wear progresses, the concentration naturally tends to increase.

Through trend analyses, it is possible to be aware of the increasing trend of the concentration at the initial wear stage and manage it as a result. Also, bear in mind that appropriate lubrication at the initial wear stage prolongs the bearing's life.

Figure A3 shows a successful example of utilizing trend management, where correct lubrication was performed when a premature lubrication trend of the bearing used in an agitator was identified.

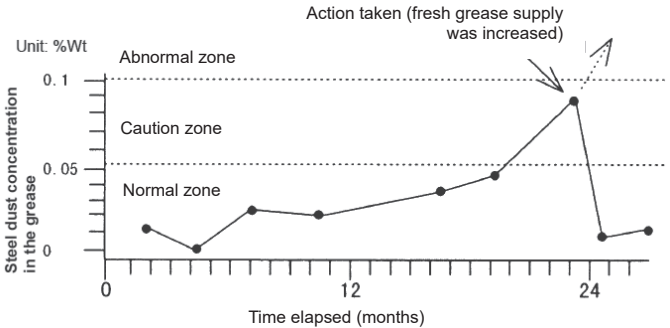

**Figure A3. Trend Management through Steel Dust Concentration Measurements**

## (6) Iron Particle Diameter and Detection Range Comparison among Measuring Methods

It is very useful to check the condition of wear particles in lubricating oil/grease as a method to diagnose and forecast the damage or wear progression of the gears and bearings.

SOAP (e.g., ICP analysis) and ferrography are commonly used for measuring the steel dust concentration in oil/grease.

Figure A4 provides a conceptual diagram of the detection range of four methods (ICP, analytical ferrography, quantitative ferrography and SDM-72/73) and the relationship between particle diameter and detected value.

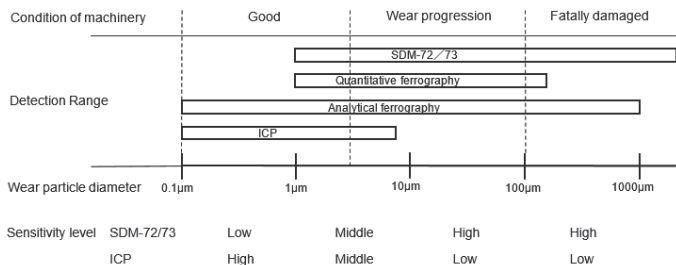

**Figure A4. Iron Particle Diameter/Detection Range Comparison**

Generally, SOAP (e.g., ICP analysis) is considered unsuitable for detecting large particles (5 µm or larger in diameter). On the other hand, the SDM-72/73 meter has high sensitivity for large particles, which directly lead to fatal damage. The use of the SDM-72/73 meter does not require any special knowledge. The SDM-72/73 meter enables the user to easily and quickly detect abnormal wear condition at an early stage and on site.

\*SOAP: Spectrometric Oil Analysis Program

\*ICP: Inductively Coupled Plasma

## (7) Comparison between SDM-Measured Values and ICP-Analyzed Values

The wear particles in oil/grease sampled from actual machinery are a mixture of various ingredients of different shapes. The quantity and properties of wear particles in an oil/grease sample differ depending on the sampling location and operating conditions, which causes the reading to vary in the end.

On placing the ICP-analysis values from smallest to largest and then comparing them with the SDM-measured values (as shown in Figures A5 and A6), the SDM-measured values are well correlated with those of the ICP-analysis. Therefore, we believe that the SDM-72/73 meter is capable enough to be used as a portable analyzer for providing a simplified preliminary diagnosis on site.

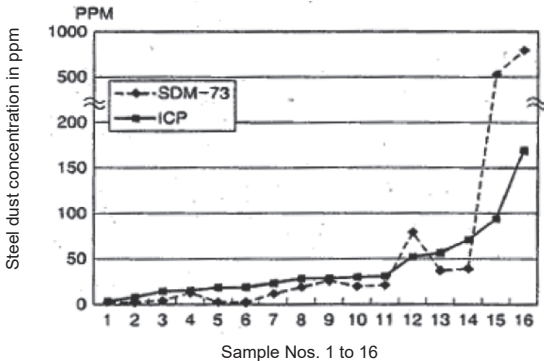

**Figure A5. Concentration Comparison between SDM-73 and ICP**

\*1. Large-peeled wear particles are mixed in Sample Nos. 15 and 16:

In the ICP analysis of a sample containing large-peeled wear particles, a large error is likely to occur. This often results in a lower reading. This phenomenon is caused as a result of the incomplete luminescent reaction of metal particles. On the other hand, the SDM-73 meter is capable of measuring a sample containing such large particles because it is designed to detect the change in permeability. It is also reported that permeability change is affected by wear particles' size and shape, for example, if needle-shaped wear particles or flattened wear particles are longitudinally lined up, the meter gives a higher reading. Normally the particles are in a random orientation, and some particles line up longitudinally to some extent, which causes the SDM-measured value to be higher than the ICP-analyzed one. This phenomenon, however, is on the safe side from the viewpoint of detecting an abnormality at an early stage. Therefore, we conclude that the use of SDM-73 meter is practical.

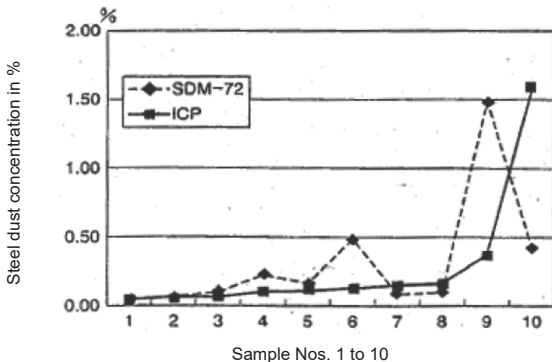

**Figure A6. Concentration Comparison between SDM-72 and ICP**

\*2. Red rust is formed in Sample No. 10:

If water enters the lubricating oil/grease and causes formation of red rust (iron oxides), it means that the polluted (rusted) wear particles have lost their magnetic properties. In this case, the SDM-72 meter gives a lower reading. Note that it is possible to visually recognize this abnormality because the sample turns iron oxide brown-red.

\*3. Fretting occurs in Sample Nos. 6 and 9:

When observed under an electron microscope, it was found that most wear particles are flattened ones having metallic luster and are large in size (250  $\mu\text{m}$  max.) That's why the ICP-analyzed value is low. Fluorescent X-ray analysis did not detect any electromagnetic materials except iron (Fe). A very small amount of manganese (Mn) was detected.

This page is intentionally left blank

### Revision History

Document No.	Date	Revision
SDM-72CEET	June 2008	Initial issue
SDM-72CEET	July 2012	01
SDM-72CEET	August 2013	02
SDM-72CEET	June 2019	03
SDM-72CEET	July 2020	04
SDM-72CEET	July 2021	05
SDM-72CEET	September 2022	06

Additional copies of this instruction manual may be purchased.  
Contact New Cosmos or its authorized representative for ordering.

**Authorized representative:**

**Manufacturer:**

NEW COSMOS ELECTRIC CO., LTD.  
2-5-4 Mitsuya-naka, Yodogawa-ku,  
Osaka 532-0036, Japan  
[www.newcosmos-global.com](http://www.newcosmos-global.com)

**NEW COSMOS ELECTRIC CO., LTD.**