

# PS-7-M series

## Extractive Pump Gas Detector (detachable sensor/sampling units)

### Instruction Manual

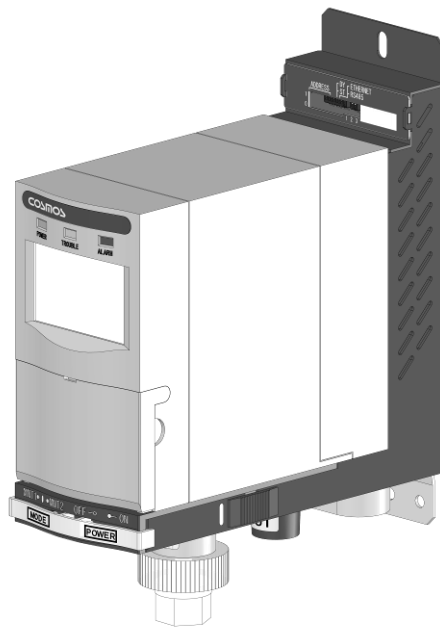

- Keep this manual for easy reference.
- Carefully read this manual prior to use.
- This manual describes the standard model. If your unit has end-user-specific options, this manual will be superseded by your delivery specifications.



**NEW COSMOS ELECTRIC CO., LTD.**

Instruction Manual No.  
GAE-138-02  
September 2022

● **Unit Dimensions and Components**

5. "Unit Dimensions and Components" on page 6.

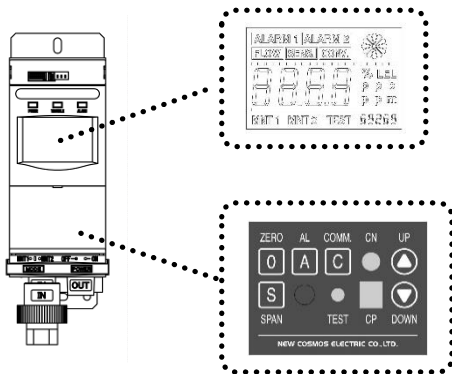

● **Sensor Unit Installation/Replacement**

9-2. "Sensor Unit Installation /Replacement" on page 41.

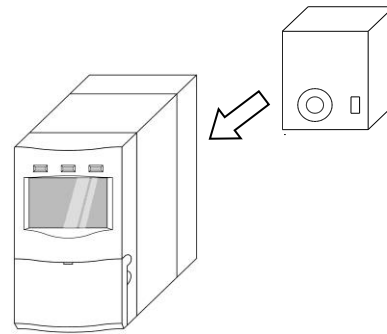

● **Base Unit installation/Wiring**

6. "Installation and Wiring" on page 12.

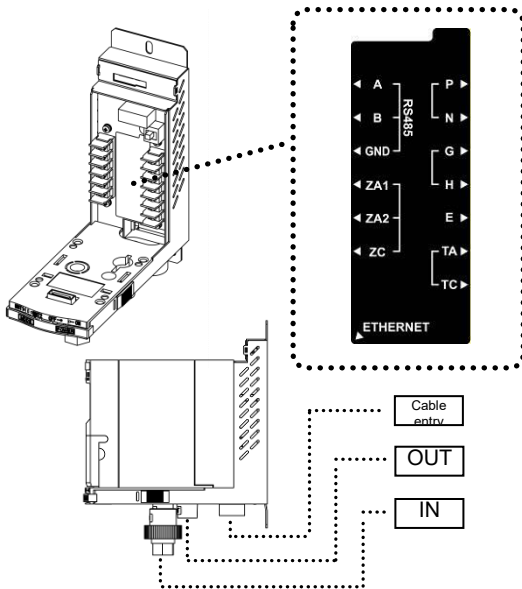

● **Operation**

7-1. "Operation" on page 19.  
For checking normal operation, refer to page 30.

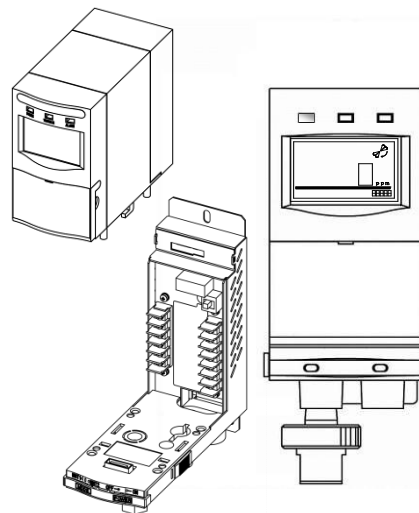

● **Gas Alarm**

7-2. "Operation - Gas Alarm" on page 30. Flashing red LED

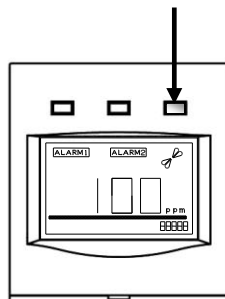

● **Trouble Alarm**

7-3. "Operation - Trouble Alarm" on pages 32. Flashing amber LED

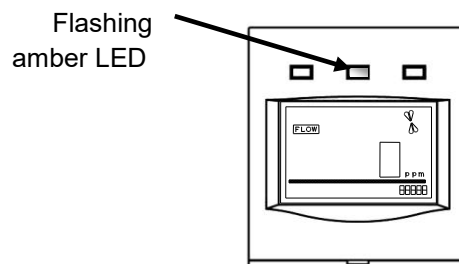

● **Troubleshooting** 10. "Troubleshooting" on page 46.

# Table of Contents

1. Introduction .....	- 1 -
1-1. Manuals and related documents .....	- 1 -
1-2. Overview .....	- 2 -
2. General Precautions .....	- 3 -
3. Package Contents.....	- 4 -
4. Block Diagram .....	- 5 -
5. Unit Dimensions and Components .....	- 6 -
5-1. Exterior Appearance.....	- 6 -
5-2. Main Unit.....	- 7 -
5-3. Base Unit .....	- 8 -
5-4. DIP Switches.....	- 9 -
5-5. Operation Buttons .....	- 10 -
5-6. LCD Indicator Icons.....	- 11 -
6. Installation and Wiring.....	- 12 -
6-1. Wiring Procedure .....	- 13 -
6-1-1 Modbus TCP (Ethernet) Wiring Procedure .....	- 15 -
6-1-2 Modbus RTU (RS-485) Wiring Procedure .....	- 15 -
6-2. Unit Installation Procedure .....	- 17 -
6-3. Tube Fitting Connection Procedure .....	- 18 -
7. Operation.....	- 19 -
7-1.Operation Procedure .....	- 19 -
7-2. Operation - Gas Alarm.....	- 30 -
7-3. Operation - Trouble Alarm .....	- 32 -
7-4. Operation - Test Mode.....	- 34 -
7-5. Operation - Maintenance Mode .....	- 35 -
8. Maintenance .....	- 37 -
9. Consumable Parts Replacement.....	- 40 -
9-1. Filter Element Replacement .....	- 40 -
9-2. Sensor Unit Installation/Replacement.....	- 41 -
9-3. Sampling Unit Replacement.....	- 44 -
10. Troubleshooting .....	- 46 -
11. Specifications.....	- 48 -
12. Warranty .....	- 50 -
13. Service Life of Detector.....	- 50 -
14. Disposal of Detector/Sensor/Sampling.....	- 50 -
15. Detection Principle .....	- 51 -
15-1. Electrochemical (Catalyst conversion) Sensor (CDS-7).....	- 51 -
15-2. Hot-wire Semiconductor Sensor (CHS-7-CH).....	- 51 -
15-3. Catalytic Sensor (CHS-7-CS).....	- 51 -
15-4. Galvanic Cell Sensor for Oxygen detection (COS-7) .....	- 51 -
16. Glossary .....	- 52 -

# 1. Introduction

## 1-1. Manuals and related documents

The following documents are prepared for use of this product.

### 1. PS-7-M series gas detector's instruction manual (This document, Doc.No.GAE-138-xx)

This document provides the following information to ensure safe use of this product.

- Safety precautions
- Installation and wiring
- Basic configuration, block diagram, unit dimensions and components
- Operation and mode setting
- Maintenance, parts replacement, and action to take in the event of a failure

A manual is provided per system and not per unit.

### 2. PS-7 gas detector's operation manual for administrators (Doc.No.GAE-019-xx)

This document is intended for your system administrator.

- Password
- Changing Settings

All the items set for this product (e.g. alarm set values) are password-protected.

A manual is provided per system and not per unit.

### 3. PS-7 pyrolyzer's operation manual (Doc.No.GAE-020-xx)

This document describes installation and replacement procedure for a pyrolyzer (sold separately).

A manual is provided per system if the system includes a sensor unit with pyrolyzer.

### 4. PS-7-M communication specifications guide

This document provides communication specifications and the configuration procedure to establish communication with external devices. This document is not included in a standard package. If needed, please contact New Cosmos or its authorized representative to obtain it.

### 5. PS-7-M IP address setting guide

This document describes how to set/change an IP address by using a web browser to establish communication with external devices. This document is not included in a standard package. If needed, please contact New Cosmos or its authorized representative to obtain it.

## 1-2. Overview



- Thank you for purchasing the New Cosmos PS-7-M series extractive pump gas detector. Prior to use, please read this instruction manual to ensure safe and reliable operation.
- This unit supports RS-485 and Ethernet communications. For information on Modbus interface communication specs, please read the PS-7-M communication specifications guide.
- This unit detects semiconductor process gas or combustible gas (e.g. hydrogen) that may be present in a cylinder cabinet, exhaust duct, or industrial facility work environment (e.g. semiconductor manufacturing plant), and relays the gas concentration value as an analog signal and a RS-485 or Ethernet signal to an external device while simultaneously displaying the gas concentration value on its display.
- If gas concentrations reach a preset level, the red ALARM LED will start flashing and activate relay contacts, thus monitoring the concentration of a leaked target gas.
- Sensor and sampling units can be easily replaced without tools. After a sensor/sampling unit replacement, on-site calibration using a prepared gas is not necessary.
- Periodic maintenance is essential to maintain the reliability of your detector. Perform periodic maintenance in accordance with the instructions given in this manual.
- PS-7-M series gas detectors are divided into three models according to the sensor unit type and with/without a pyrolyzer. For sensor selection, please contact New Cosmos or its authorized representative.

Sensor unit (sold separately)	Model
Toxic gas sensor unit (CDS-7)	PS-7-M-01
Combustible gas sensor unit (CHS-7)	
Oxygen (COS-7)	PS-7-M-02
Toxic gas sensor unit (CDS-7) with pyrolyzer (CDP-7)	PS-7-M-03

- This product is CE-marked, but its RS-485 communication function is outside the scope of the CE marking.
- Modbus® is a registered trademark owned by Modicon Inc. (Schneider Automation international).

## Symbols Used in this Instruction Manual

This manual uses Danger, Warning, Caution and Note symbols to draw attention to procedures, materials, methods, and processes, which require particular attention.

 <b>DANGER</b>	Indicates an imminently hazardous situation that can result in death or serious injury.
 <b>WARNING</b>	Indicates a potentially hazardous situation that may result in death or serious injury.
 <b>CAUTION</b>	Indicates a hazardous situation that may result in minor injury or property damage.
<b>NOTE</b>	Provides information on product handling.

## 2. General Precautions

- Carefully read this manual prior to use.
- To ensure safe operation, follow the precautions below.
- Wiring and installation should only be performed by a qualified electrician with knowledge of wiring/installation procedures.



### **DANGER**

- This product is not explosion-proof equipment and should not be installed in a hazardous area.



### **WARNING**

- In the event of a gas leak alarm, follow safety procedures in accordance with your company's regulations.
- Ground the detector to prevent electric shocks.



### **CAUTION**

- Do not disassemble, modify, or alter the structure of this unit or its electrical circuits. Doing so may compromise the performance of the product.
- This product is not drip-proof equipment and should be kept away from splashing water.
- Only use this product in accordance with applicable laws and regulations.

### 3. Package Contents

The following items are included in a standard package. If any items are missing or damaged, please contact New Cosmos or its authorized representative for replacement.

Table 1. Standard contents

Item Name	Qty.
Gas detector (PS-7-M)	1
Half union (male connector) R1/4- ø6mm or R1/4- ø1/4 in. (selectable) *1	2
Replacement filter elements (FE-1, 12 pcs.) for MF-50 filter unit	1
Replacement fuse (1.0 A)	1 *2
Mounting screws (M4×8)	3
Outlet spacer	1
Mounting plate	1
Test stick	2 *3
Instruction manual (this document)	1 *4
PS-7 gas detector's operation manual for administrators (Doc.No.GAE-019-xx)	1 *4
PS-7 pyrolyzer's operation manual (Doc.No.GAE-020-xx)	1 *5

\*1. Specified during order placement. Unspecified orders ship with R1/4- ø6 mm.

\*2. Replacement fuse.

\*3. Two pcs. per system.

\*4. One pc. per system.

\*5. One pc. is provided per system including a sensor unit with a pyrolyzer.

Note: Sensor units are sold separately, and not included in "Standard contents".

Table 2. Optional items (sold separately)

Item Name	Qty.
Filter unit (MF-51)*6	As ordered.
Gas collector (PF-D1)	As ordered.

\*6. Recommended when monitoring adsorbable gas (e.g. HCl, Cl<sub>2</sub>, NH<sub>3</sub>) other than HF and F<sub>2</sub>.

## 4. Block Diagram

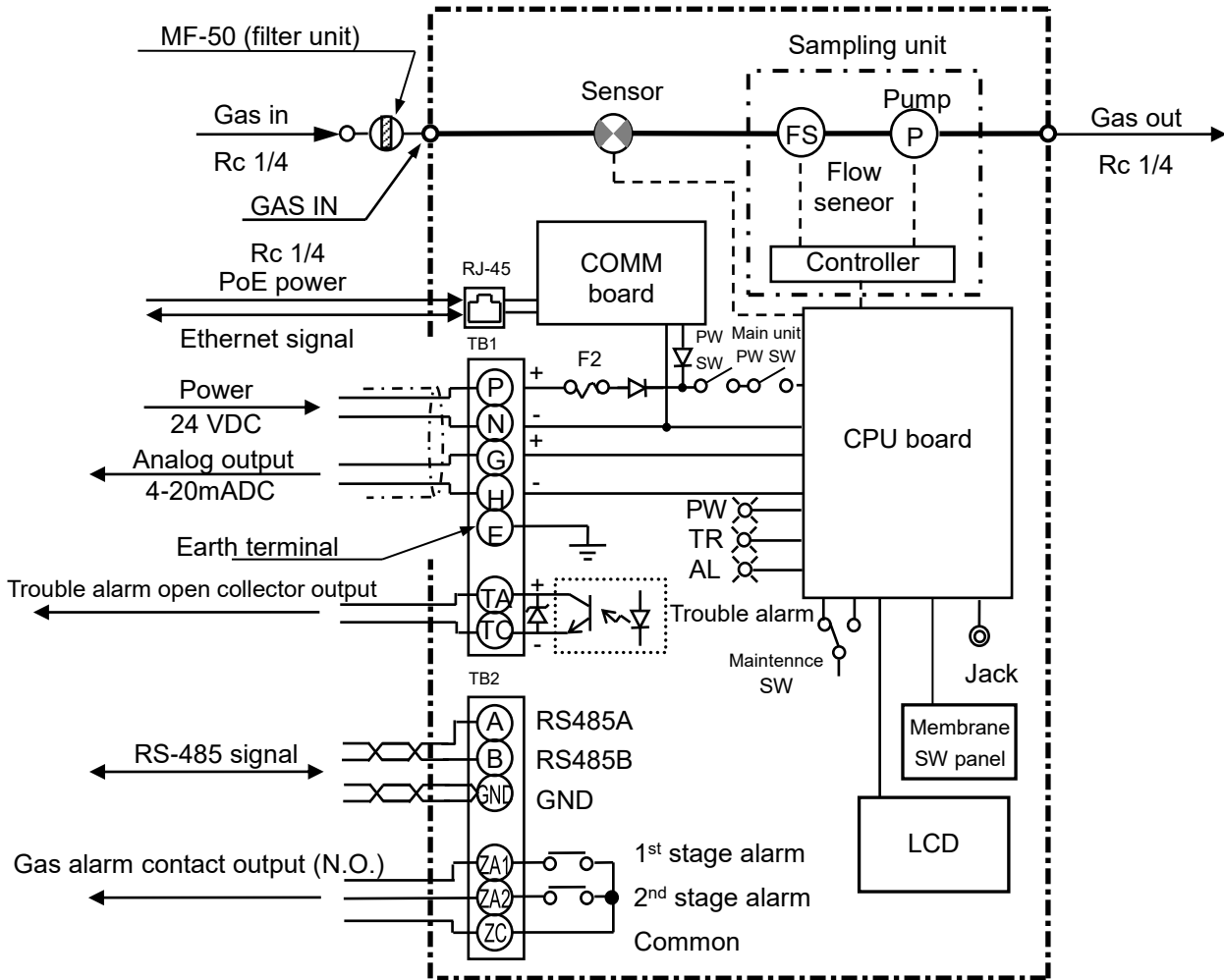

Max. load: 30 VDC 0.5 A (resistive load) for gas alarm contact (ZA1 or ZA2-ZC)  
 Max. load: 30 VDC 30mA (resistive load) for trouble alarm open collector output (TA-TC)

### **WARNING**

- Turn off the gas detector before starting wiring to prevent electric shocks.
- Ground the gas detector to prevent electric shocks.
- Ensure open collector output is connected (TA: + / TC: -). Due to the built-in protection diode, incorrect polarities will cancel an active trouble alarm output.

### **CAUTION**

- The analog output line and power line of the gas detector are not isolated from each other. When using with external devices, provide isolation to prevent noise from other power lines from interfering with the analog output of the detector.
- When wiring, place wires to avoid potential noise sources (e.g. large power transformers, motors, and powers supply units).
- Ensure cables between the gas detector and external devices are connected correctly.



## 5. Unit Dimensions and Components

### 5-1. Exterior Appearance

#### PS-7-M-01/02

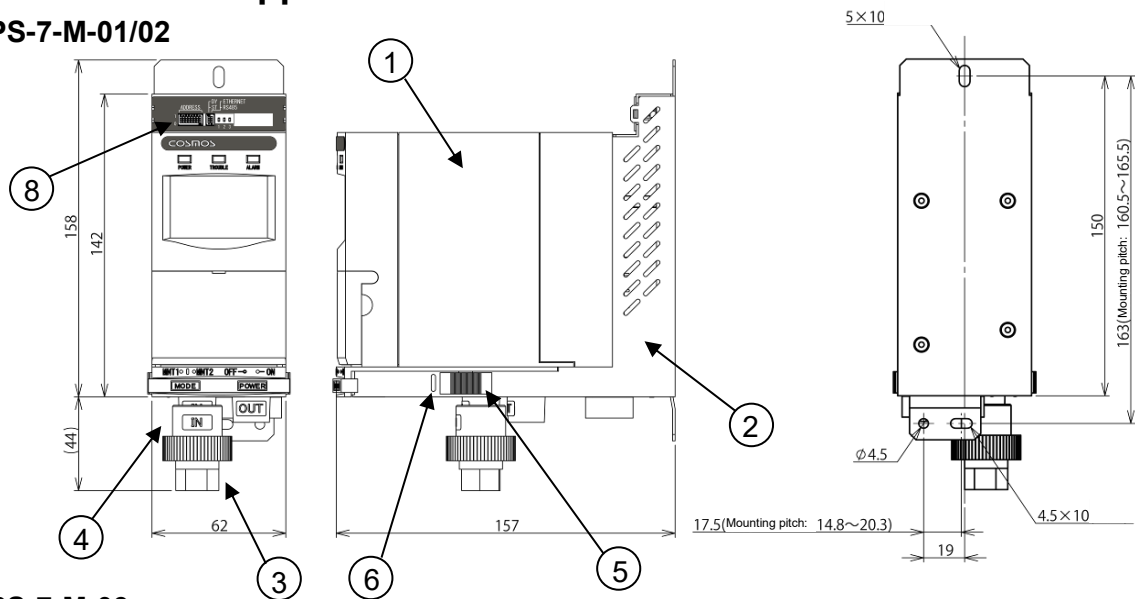

#### PS-7-M-03

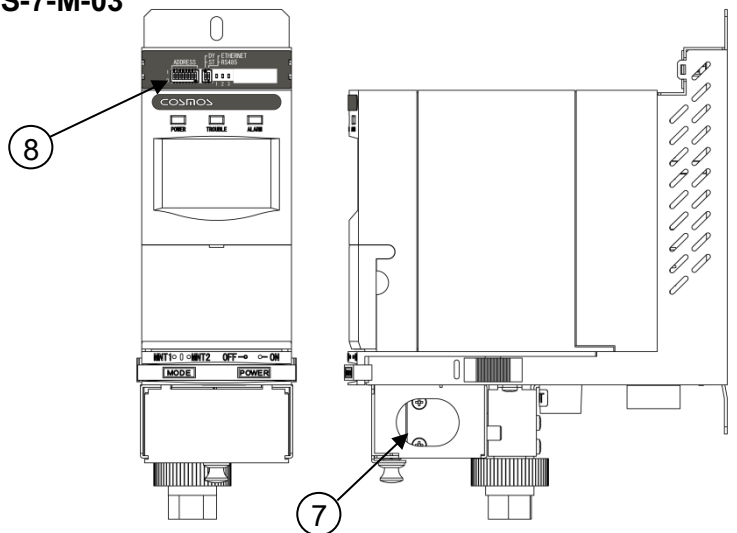

(Dimensions are in mm)

Item	Component	Description/Function
1	Main unit	Includes a display, a pump and a sensor.
2	Base unit	Thread cables thru the cable entry hole on the bottom of the base unit and connect to the main unit
3	Filter unit (MF-50)	Incorporates a filter element (FE-1) that prevents dust from entering the gas inlet and traveling into the sensor.
4	Inlet spacer	Prevents the filter unit from being over tightened.
5	Latch (2 places)	Latches secure the main unit to the base unit.
6	White line (2 places)	Indicates that the latch is in the lock position.
7	Pyrolyzer	Refer to "PS-7 pyrolyzer's operation manual" (separate document).
8	DIP switches	Used for setting IP address/unit ID and communication mode. Refer to 5-4. "DIP Switches".

## 5-2. Main Unit

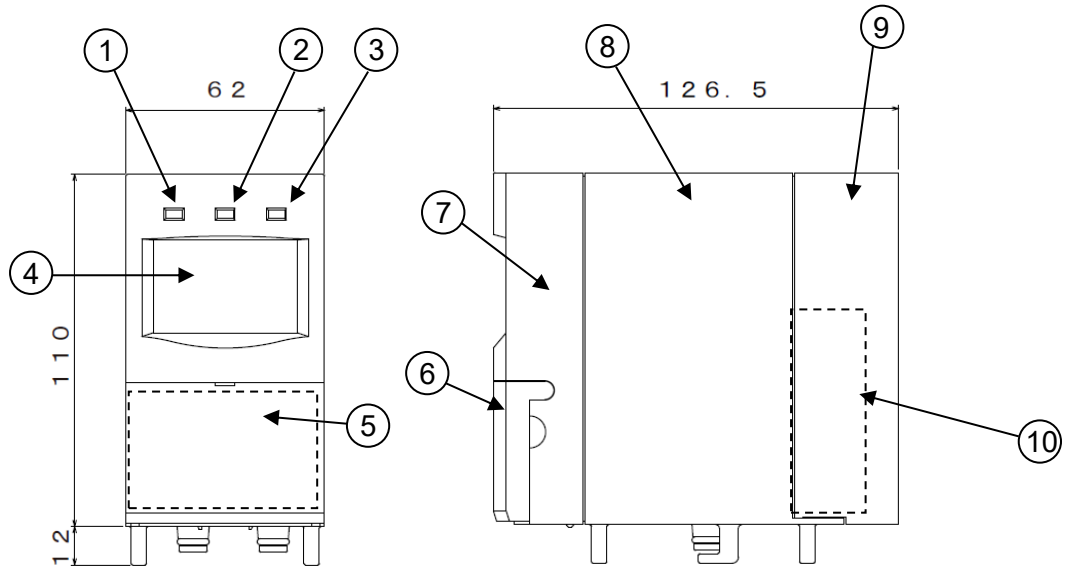

(Dimensions are in mm)

Item	Component	Description/Function
1	Green POWER LED	When lit, the unit is in normal operation mode (gas-monitoring mode).
2	Amber TROUBLE LED	Flashing indicates an internal failure is present.
3	Red ALARM LED	Flashing indicates a gas alarm is present.
4	LCD	Displays alarm notification, numeric gas concentration value, gas concentration on bar graph, trouble status, maintenance/test mode, and flow rate status.
5	Operation buttons (covered)	Setting/adjustment buttons and TEST switch.
6	Front cover	Gently pull out and slide down to access the operation buttons.
7	Front panel	Incorporates a built-in main board.
8	Sampling unit	Incorporates a built-in pump unit.
9	Rear cover	Protects a built-in sensor unit.
10	Sensor unit	Remove the rear cover to remove/install a sensor unit.

### 5-3. Base Unit

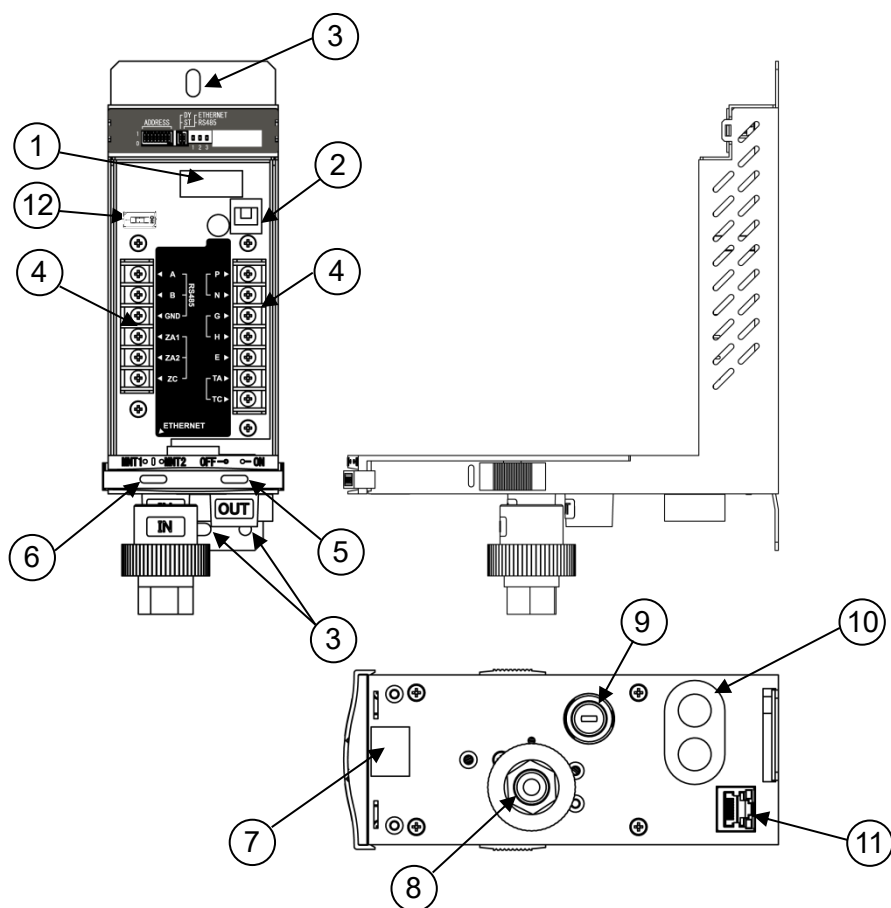

Item	Component	Description/Function
1	Fuse	Internal circuit protection.
2	Base unit power switch	Turns on/off the base unit.
3	Mounting hole	φ5.5 mm
4	Terminal block (2 places)	Used for external wiring.
5	Main unit power switch	Turns on/off the main unit. Note: If the base unit power switch is off, no power is supplied to the main unit.
6	Maintenance switch	Switches between the maintenance mode 1 (MNT1), maintenance mode 2 (MNT2), and normal operation mode.
7	Pyrolyzer connector	Supplies power to a connected pyrolyzer (CDP-7).
8	Gas inlet	Thread size: Rc1/4 Filter unit (MF-50) is attached to this inlet.
9	Gas outlet	Thread size: Rc1/4
10	Grommet	Holds signal and power cables.
11	RJ-45 jack	Connect a LAN cable to the RJ-45 jack.
12	Terminal resistor switch	Turns on/off the terminal resistor. Set the switch to the ON position to connect both ends of the circuit. Refer to "PS-7-M communication specifications guide" (separate document).

## 5-4. DIP Switches

### CAUTION

- Set the base unit power switch to the OFF position before using the DIP switches to avoid incorrect operation or device failure.
- Do not use IP address “255 (1111 1111)” because LAN Communication will be disabled if that IP address is used.
- Set the DIP switches in accordance with your selected communication method. Refer to the PS-7-M communication specifications guide for details.
- Ensure that each switch is clearly set to the 1/0, DY/ST, and Ethernet/RS485 positions. Unclear setting may result in incorrect operation/communication.

#### NOTE

- The IP address settable range is 1 (0000 0001) to 254 (1111 1110).
- When the IP address is “0 (0000 0000)”, it will be superseded by the IP address set by a web browser.
- IP address can be set to any value within the settable range, but if the same address is used by more than one detector, the relevant detectors cannot communicate.

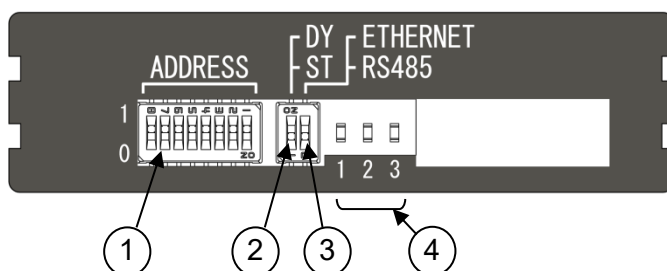

Item	Component	Description/Function
1	IP Address setting switches	Set the IP address for this product. Settable range: 1 (0000 0001) to 254 (1111 1110). <ul style="list-style-type: none"> <li>● Modbus TCP (Ethernet): Set the 4th value of IP address. *1</li> <li>● Modbus RTU (RS-485): Set the unit ID.</li> </ul>
2	IP address type switch	Switches the IP address method between DY and ST. DY: Dynamic IP address (DHCP) ST: Static IP address
3	Mode change switch	Switches the mode between Ethernet and RS485. ETHERNET: MODBUS TCP RS485: MODBUS RTU (RS-485)
4	Status LED-1/2/3	Indicates the unit and communication statuses. 1: When flashes, LAN cable is securely connected to RJ-45 jack. 2: When flashes, Ethernet and RS-485 communications are in progress. 3: Communication status between the base and main unit. <ul style="list-style-type: none"> <li>- When flashes, communication is normal (sending and receiving)</li> <li>- When steady, no response from the main unit.</li> <li>- When not lit, no request from the base unit.</li> </ul>

\*1: When the IP address is “0 (0000 0000)”, the IP address can be changed by using a web browser.

## 5-5. Operation Buttons

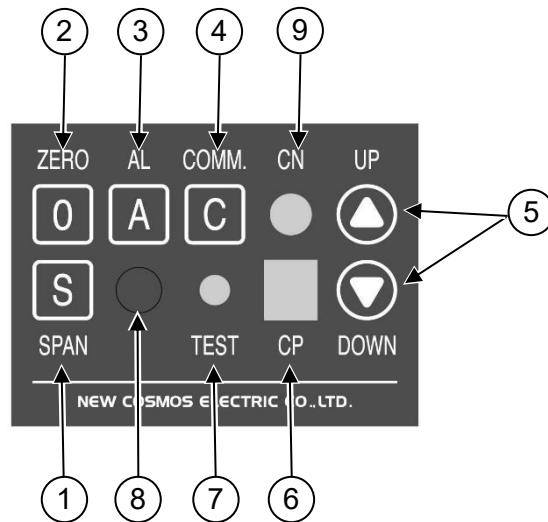

### Opening front cover

Pull and slide down the front cover to access the operation buttons and TEST switch.

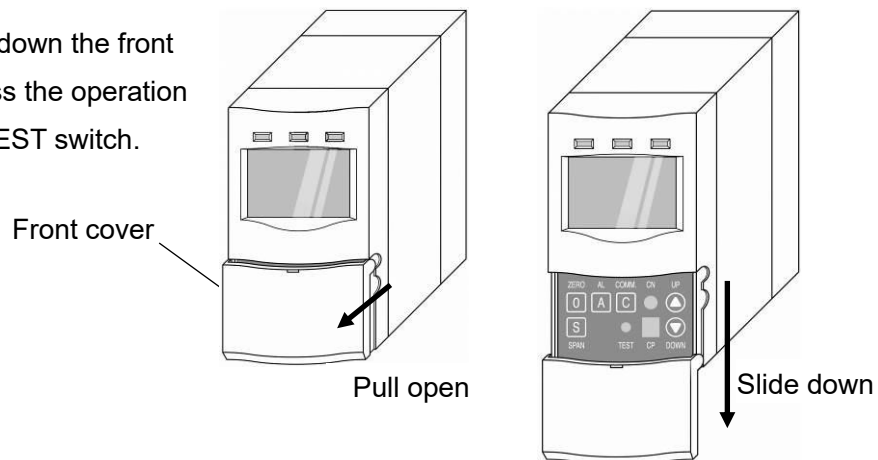

Item	Component	Panel marking	Description/Function
1	SPAN button (Span adj. button)	SPAN	Performs span adjustment. For O <sub>2</sub> sensor unit (COS-7), 21%vol adjustment will be performed.
2	ZERO button (Zero adj. button)	ZERO	Performs zero adjustment for toxic/flammable gas sensor unit (CDS-7/CHS-7)
3	AL button (Alarm setting check button)	AL	Used to check the alarm set values.
4	COMM. button	COMM.	Imports data from a currently inserted sensor at initial startup, etc.
5	UP and DOWN buttons	UP/DOWN	Increase/decrease the parameter value.
6	Analog output check connector	CP	Dedicated connector to check the unit's 4-20 mA analog output.
7	TEST switch	TEST	Sets the unit to the test mode.
8	Button for administrator use		(Administrator use)
9	Communication connector	CN	(Unused)

## 5-6. LCD Indicator Icons

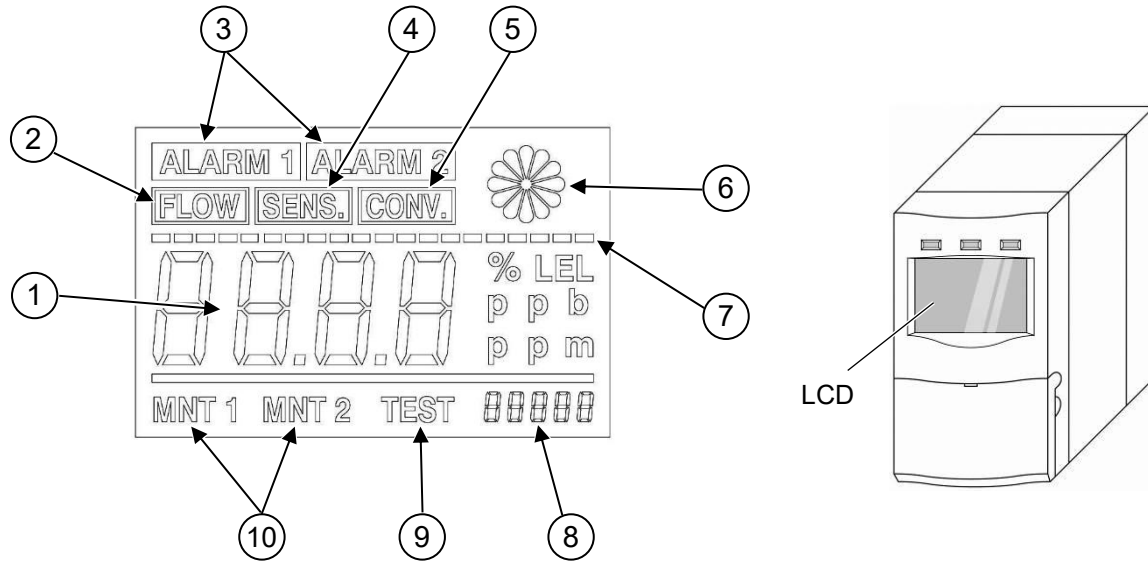

Item	Icon/Display	Description/Function
1	Numeric display	Displays gas concentration and the unit of measurement. E.g. %LEL, ppb, ppm
2	FLOW	Flow rate is low. Linked with item 6.
3	ALARM1 ALARM2	1 <sup>st</sup> and 2 <sup>nd</sup> stage gas alarms.
4	SENS.	A sensor fault (e.g. broken wire) is present or incorrect sensor unit is inserted.
5	CONV.	Broken pyrolyzer wire.
6	Flow rate	Represents the flow rate of sampled gas. - Spinning fast: Flow rate is normal. "FL500" indicated on sub-display. - Spinning slowly: Flowrate is reduced. Possible filter/tube clogging. "FL400" or less indicated on sub-display. - Stopped: Flow rate is too low. Low flow rate alarm. "FL300" or less indicated on sub-display.
7	Gas concentration on bar graph	One bar represents 5% of the full scale value. The bar graph value increases from left to right with the far right being full scale value.
8	Sub-display	Displays information on setting, flow rate, etc. (Administrator use)
9	TEST mode	Unit is in test mode.
10	MNT1 / MNT2 mode	Unit is in maintenance mode 1 or 2.

## 6. Installation and Wiring



### DANGER

- This product is not explosion-proof equipment and should not be installed in a hazardous area.



### WARNING

- For detection of adsorptive gas (e.g. HF and F<sub>2</sub>), remove the filter element (FE-1) from the filter unit (MF-50). Correct detection is not possible if the filter element is present. Refer to 9-1. "Filter Element Replacement".
- Tubing should be Teflon,  $\phi 6/4$ , and less than 20m in length. For adsorptive gases (e.g. HF, F<sub>2</sub>, HCl, Cl<sub>2</sub>, NH<sub>3</sub>), the tube length should be less than 5m.
- Set the main unit power switch (located on the front of the base unit) to the OFF position before installing/removing the main unit. Installation/removal while the main unit power switch is in the ON position may cause a false alarm or device failure.



### CAUTION

- Install the gas detector in a place free from impact and vibration.
- Do not install in the vicinity of equipment which can generate high frequencies or a magnetic field.
- Do not use a gas collector in a confined space (e.g. inside a duct).
- Do not install the gas detector in a high temperature (higher than 40°C) and condensation-prone area. Avoid sudden temperature changes.
- This product is not drip-proof equipment and should be kept away from splashing water.
- Do not block the cooling vents on both sides of the base unit.
- The pressure differential between the gas inlet/outlet and the outside air pressure (atmospheric pressure) should be within  $\pm 1$ kPa. In addition, the pressure differential between the gas inlet and the gas outlet should be within 1kPa, with negative pressure applied to the gas inlet. Using the detector under overpressure will cause an excess flow, which may result in flow rate error or incorrect measurement.
- This unit is precision equipment. Stress or impact to the base unit should be avoided.
- Install the gas detector vertically with its gas inlet and outlet facing down.
- Determine the height for the tip of sampling tube by considering the specific gravity of the target gas, and install the gas detector where gas is expected accumulate.

Gas type	Installing height
Gas heavier than air	Maximum of 30 cm above the floor
Gas near the specific gravity as air	75 to 150 cm above the floor
Gas lighter than air	Near the ceiling

**NOTE**

- When installing the gas detector, ensure there is enough space below/above the detector to allow for installation/removal/wiring activities. (Recommended: More than 100mm above the unit and 150mm below the unit.)
- When installing more than one detector side by side, make sure to leave enough space right and left to the gas detector to allow for installation/removal of the main unit. (Recommended: More than 30mm right and left to the unit.)

## 6-1. Wiring Procedure



### WARNING

- Turn off the gas detector before wiring to prevent electric shocks.
- Ensure open collector output is connected (TA: + / TC: -). Due to the built-in protection diode, incorrect polarities will cancel an active trouble alarm output.



### CAUTION

- The analog output line and power line of the gas detector are not isolated from each other. When using the detector with external devices, provide isolation to prevent noise from other power lines from interfering with the analog output of the detector.
- When wiring, place wires to avoid potential noise sources (e.g. large power transformers, motors, and powers supply units).
- Ensure cables between the gas detector and external devices are connected correctly.
- Gas alarm contact output is intended to be used with resistive loads only. If used with inductive loads, high voltage surge will be generated resulting in damage to the device or relay contacts.
- Turn off the gas detector before fuse replacement.
- Keep the connection cables (power and signal lines from the detector) away from other power lines.
- When wiring, place wires to avoid mechanical stress on the wiring.



Marking on board	Polarity	Function *1	Recommended cable *2
P	+	Power input (24 VDC)	2-core CVV cable
N	-		
G	+	Gas concentration output (4-20 mADC)	3-core CVVS cable
H	-		
E		Earth terminal	
TA	+	Trouble alarm (Open collector: N.C.) Max. load: 30 VDC, 30mA resistive load	2-core CVV cable
TC	-		
A	+	Digital signal (RS-485)	2-core shielded twisted pair cable
B	-		
GND			
ZA1		1 <sup>st</sup> stage gas alarm contact output (Dry N.O. contact) Max. load: 30 VDC 0.5 A resistive load	3-core CVVS cable
ZA2			
ZC		ZA1, ZA2 Common	

\*1. N.C. Normally Closed. N.O. Normally Open.

\*2. Applicable cable: Dia. 8-11mm x 2pcs. Use appropriate cables for the installation environment.

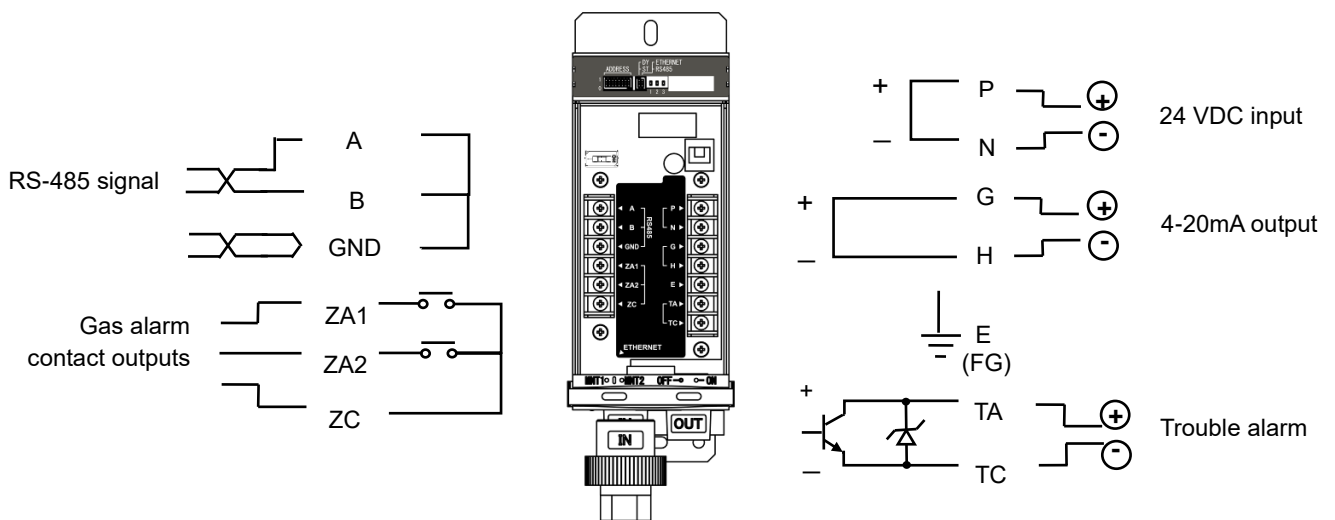

**Terminal layout**

## 6-1-1 Modbus TCP (Ethernet) Wiring Procedure

Establishing Modbus TCP communication

### **WARNING**

- When using the 24 VDC power supply, ensure that the power is 24 VDC  $\pm$ 10%.
- When using the PoE power supply, ensure that the LAN cable is securely connected.

#### **When PoE-HUB is connected,**

- (1) Insert a LAN cable to the RJ-45 jack located at the bottom of the base unit.

### **CAUTION**

Turn off the PoE before disconnecting the LAN cable from the RJ-45 jack.

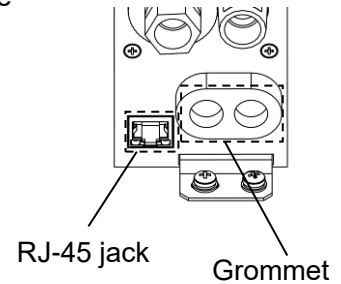

- (2) Run a signal cable thru the grommet (located at the bottom of the base unit), and connect the cable wires to their corresponding terminals (refer to "Terminal layout" on page 14).

#### **When 24VDC power supply is used without a connected PoE-HUB**

- (1) Insert a LAN cable into the RJ-45 jack located at the bottom of the base unit.
- (2) Run power and signal cables thru the grommet (located at the bottom of the base unit), and connect the cable wires to their corresponding terminals (refer to "Terminal layout" on page 14).

## 6-1-2 Modbus RTU (RS-485) Wiring Procedure

Establishing Modbus RTU (RS-485) communication

### **WARNING**

- When using the 24 VDC power supply, ensure that the power supply is 24 VDC  $\pm$ 10%.

### **CAUTION**

- Applicable cables: Dia.8-11mm x 2pcs. Use appropriate cables for the installation environment.

- (1) Run a power cable thru the grommet (located at the bottom of the base unit), and connect the cable wires to their corresponding terminals (refer to “Terminal layout” on page 14).
- (2) Run a RS-485 digital signal cable thru the grommet (located at the bottom of the base unit), and connect the cable wires to their corresponding terminals (refer to “Terminal layout” on page 14).

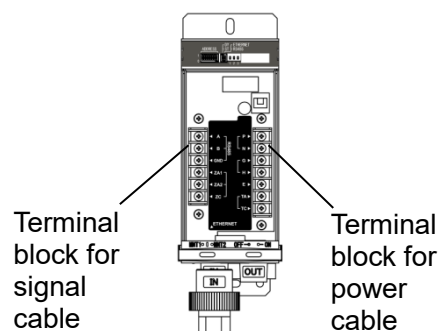

**NOTE**

- Use shielded twisted pair cable for RS-485 wiring. Cable length: Max.1.2 km
- Single-point grounding (grounding at a single point) is mandatory. When the cable shield from the gas detector is grounded on the power supply side, DO NOT ground the shield cable to the Earth terminal located inside the gas detector (on the terminal block for power cable) to avoid 2-point grounding..

Requirements for LAN cable

- Use unshielded twisted pair (UTP) LAN cable, solid wire, category 5e or higher.
- Do not use a flat type twisted pair LAN cable.
- If used in a place exposed to electrical noises, use a shielded twisted pair (STP) cable for added resistance to external interference.
- Cable length: Max.100 m
- Refer to the separate PS-7-M communication specifications guide.

## 6-2. Unit Installation Procedure

1. Determine where to place the base unit (positioning). Secure the mounting plate to the wall with the two mounting screws (M4x8).
2. Anchor the base unit to the mounting plate by inserting the mounting plate into the slot on bottom of the base unit, and secure using the mounting screw (M4x8).

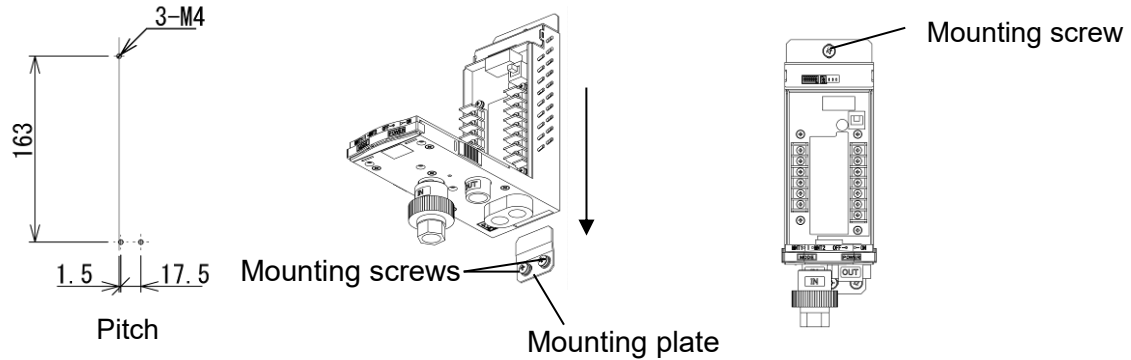

3. To install the sensor unit at this time, refer to 9-2. "Sensor Unit Installation/Replacement".  
To install the sensor unit at later stage, move to step 4.

4. Ensure that the main unit power switch is in the OFF position.
5. To install the main unit, pull forward and hold both latches of the base unit. Connect the main unit by sliding it onto the rails of the base unit.

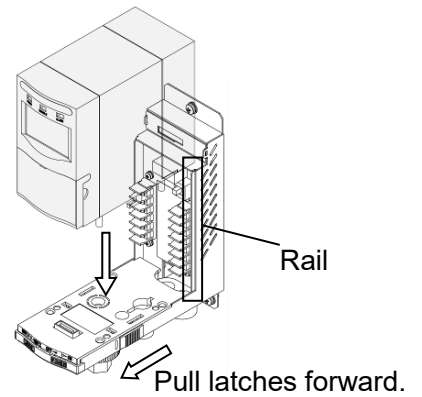

6. Push the base unit's latches back into place so that the white lines are visible, indicating the latches have been locked.

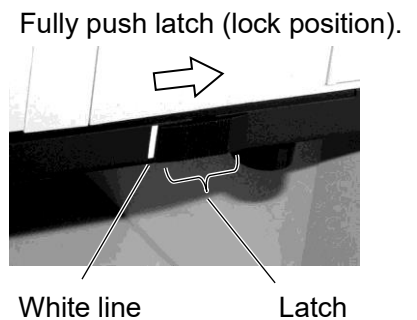

### WARNING

- Ensure that the latches are in the fully locked position (white lines visible). Normal detection is not possible if the latches are not fully locked.

### 6-3. Tube Fitting Connection Procedure

Install the provided half union tube fitting into the filter unit inlet and gas outlet.

#### CAUTION

- Over tightening the filter unit inlet may break the gas inlet. When connecting the provided half union to the filter unit inlet, secure the filter unit inlet with one adjustable wrench or spanner, etc. to prevent filter unit inlet from rotating and another to install the half union.

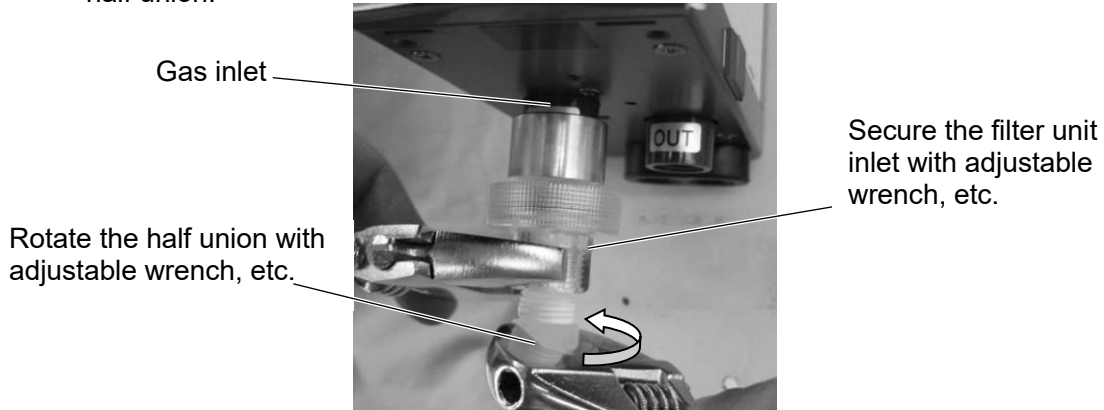

When metal tube fittings (not provided) need to be installed into the filter unit inlet and gas outlet.

#### CAUTION

- Over tightening metal tube fittings may break the gas outlet. To prevent this, install the provided gas outlet spacer to the gas outlet first, then connect the metal tube fitting over the spacer.
- Use metal tube fittings (Swagelock SS-6MO-1-4RT or equivalent) for both gas inlet and outlet.
- Wrap sealing tape tautly around the threads of each metal tube fitting to prevent slack (approx.2.5 wraps).  
Tape size: 13mm (width) x 100±5mm (length) x 0.1mm(thickness)  
Tighten the metal tube fitting until hand-tight. Do not over tighten the tube fitting or the gas outlet may break.

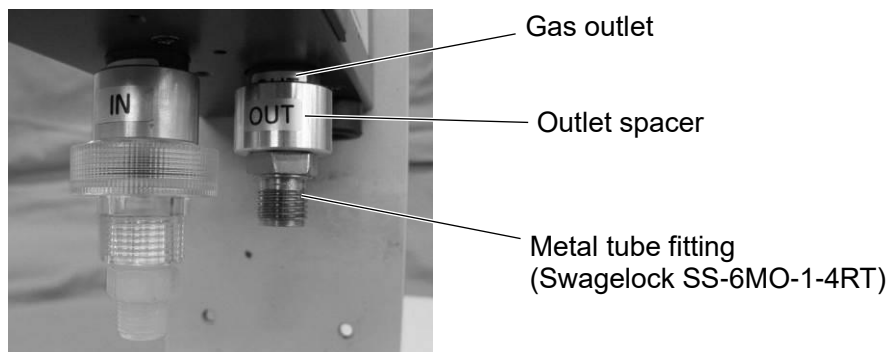

# 7. Operation

## 7-1.Operation Procedure

### Operation Flow

Corresponding numbered steps are given for items 1 to 13 on the following pages.

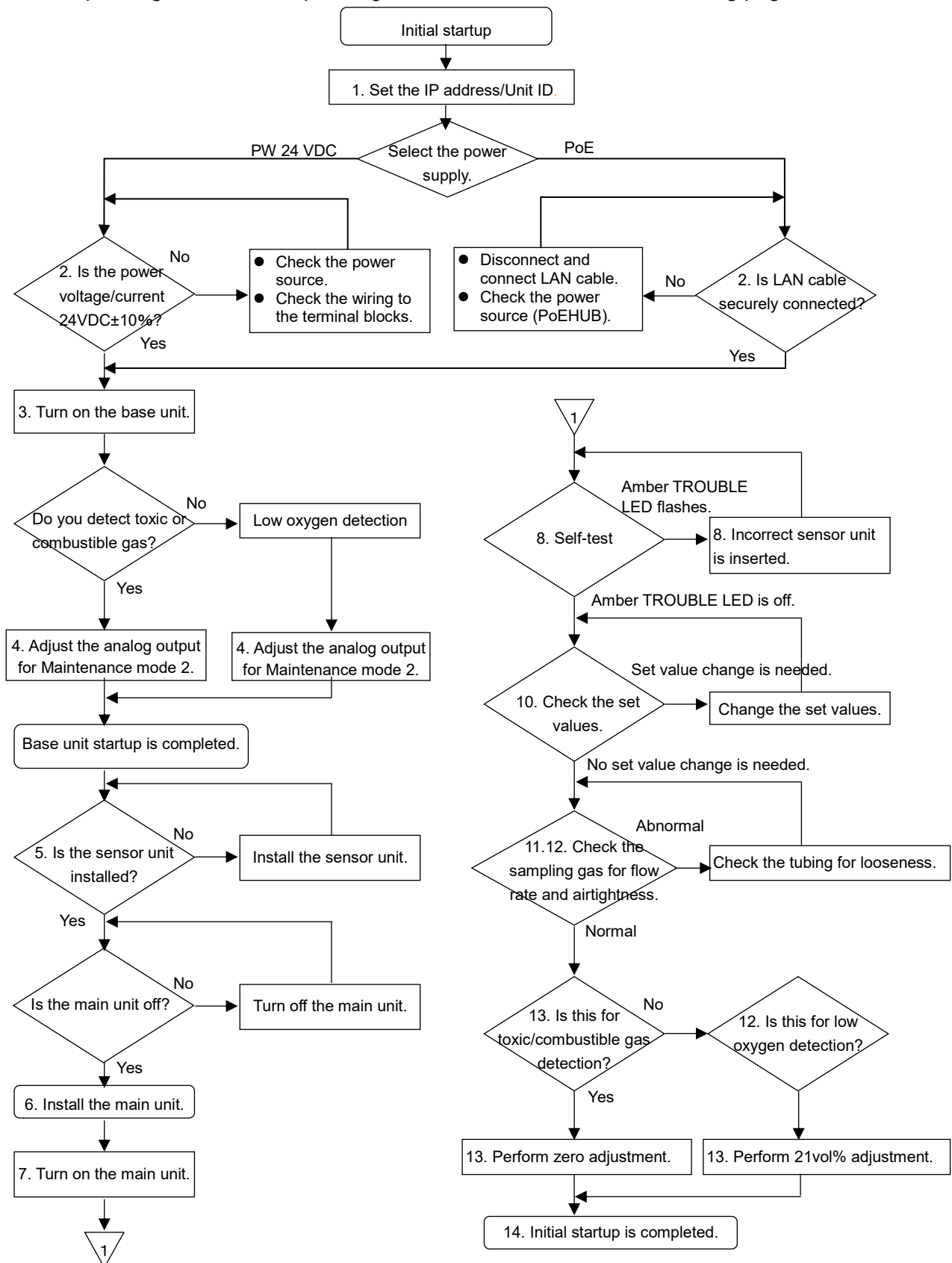

## Operation Steps

Operate the gas detector by taking the following steps.

### **WARNING**

- When using the 24 VDC power supply, ensure that the power is 24 VDC  $\pm$ 10%.
- When using the PoE power supply, ensure that the LAN cable is securely connected.
- Check that the target gas type and full scale value are correct before using a new sensor unit. Also, check that the sensor unit expiration date has not been reached.

### **CAUTION**

- Before turning on the gas detector, check that all wiring is correct. Refer to 6-1. "Wiring Procedure" and your delivery specifications if your unit has end-user-specific options.

1. Set the IP address/Unit ID.

Modbus TCP communication requires that the 4th value of the IP address to be set.

RS-485 communication requires the Unit ID (slave address) to be set.

Remove the address plate to access the DIP switches and set the IP address or Unit ID.

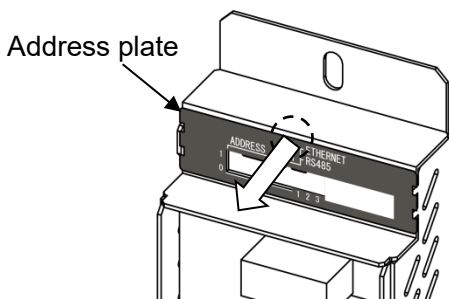

Pull the center of the plate with finger to remove it from the base unit.

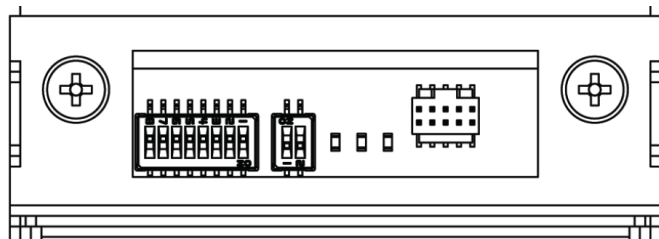

DIP switches are accessible when the plate is removed.

### **CAUTION**

- Set the base unit power switch to the OFF position before using the DIP switches to avoid incorrect operation or device failure.
- Do not use IP address "255 (1111 1111)" because LAN Communication will be disabled if that IP address is used.

**NOTE**

- The IP address settable range is 1 (0000 0001) to 254 (1111 1110).
- When the IP address is "0 (0000 0000)", it will be superseded by the IP address set by a web browser. Refer to "PS-7-M IP address setting guide" (separate document) for IP address change.
- IP address can be set to any value within the settable range, but if the same address is used by more than one detector, the relevant detectors cannot communicate.
- Ensure that each DIP switch is clearly set to 1 or 0 position. A switch in an unspecified position will cause unintended setting and incorrect operation/communication.
- Refer to "PS-7-M IP address setting guide" (separate document) for full information.

**To set the address with a web browser:**

It is possible to set/change the IP address by using a web browser. Refer to "PS-7-M IP address setting guide" (separate document) for full information.

**To set the address with the gas detector:**

Setting procedure is as follows.

- (1) Set the right two DIP switches (1) to "ST" (Static IP address) and "ETHERNET" (Modbus TCP communication) respectively.
- (2) Set the 4th value of the IP address by using the left eight DIP switches (2).  
The IP address is entered in binary form. E.g. "0000 1001" = "9"

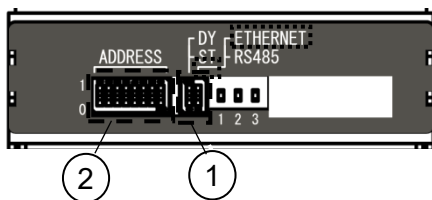
**2. When 24 VDC power supply is used**

Check that the power voltage (between P and N on the terminal block) is 24 VDC  $\pm$ 10%.

**When PoE is used**

Check that the status LED-1 flashes.

Note: The status LED-1 is off when the LAN cable is not securely connected.

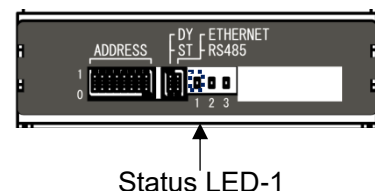



- Set the base unit power switch to the ON position.

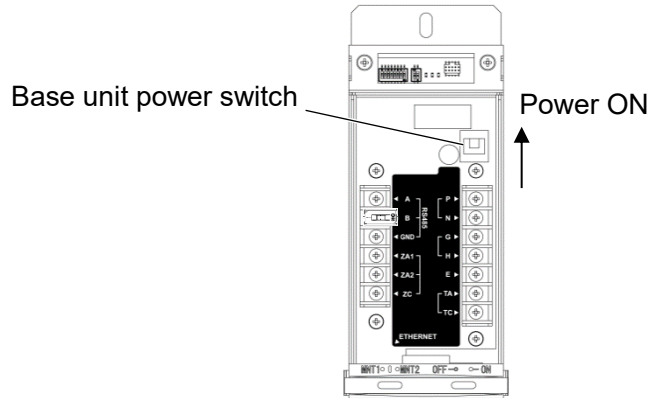

- Adjust the analog output for the maintenance mode 2 (MNT2).

The maintenance mode 2 analog output varies depending on the sensor unit type. Therefore, the output needs to be adjusted by taking the following steps. Refer to 7-5. "Operation - Maintenance Mode" for full information on the maintenance mode.

- Lift the cover flap open. Set the maintenance switch to the MNT2 position.

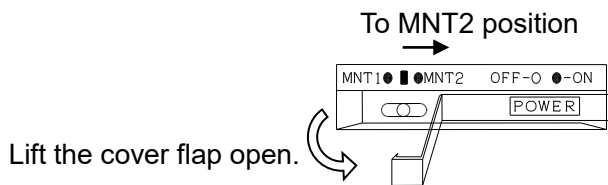

- Adjust the analog output level.

Toxic gas sensor (CDS-7)
Combustible gas sensor (CHS-7)
Oxygen sensor (COS-7, FS: 25vol%)

Measure the analog output (current) between the "G" and "H" terminals with a multimeter, etc.

If the output level is within the range below, go to step (3). If not, adjust it using the trimmer.

Sensor unit model	Adjustable range
CDS-7	3.92-4.08mA
CHS-7	3.92-4.08mA
COS-7	17.32-17.48mA

Oxygen sensor (COS-7, FS: 50vol%)
-----------------------------------

Measure the analog output (current) between the "G" and "H" terminals with a multimeter, etc.

If the output level is within the range below, go to step (3). If not, adjust it using the trimmer.

Sensor unit model	Adjustable range
COS-7 (FS: 50%)	10.64-10.80mA

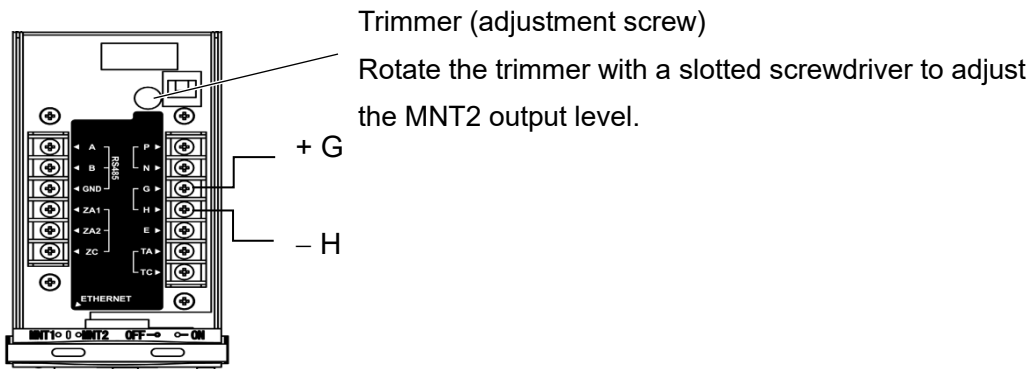

**NOTE**

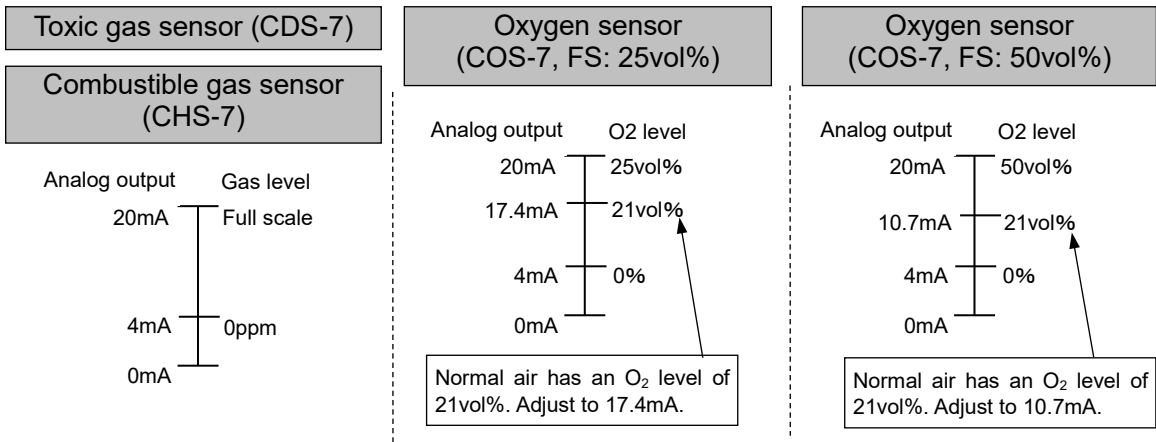

(3) Set the maintenance switch to the center position (normal operation mode).

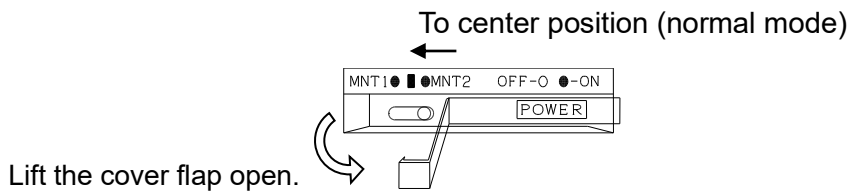

5. Install the sensor unit if it is not installed yet. For installation procedure, refer to 9-2. "Sensor Unit Installation/Replacement". Ensure the main unit power switch is in the OFF position before sensor unit/main unit installation.

6. Install the main unit to the base unit. For installation procedure, refer to 6-2. "Unit Installation Procedure".

- 
7. Set the main unit power switch to the ON position.

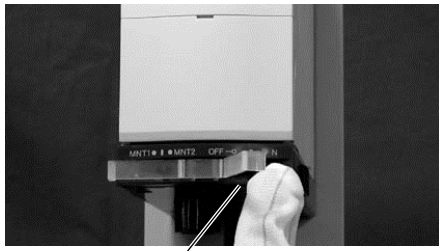

Main unit power switch

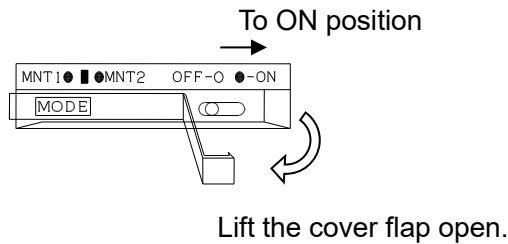

- 
8. All the LEDs on the front and the LCD turn on for one second, then the gas detector starts self-test.

- When this product is used for the first time or a different gas type/setting of sensor unit is installed (e.g. target gas or full scale value is different), the TROUBLE LED will flash, [SENS.] will appear and “Err” will be shown on the sub-display. Open the front cover and press the COMM. button for more than one second to clear the error.

TROUBLE LED flashing

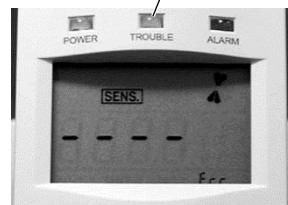

COMM. button

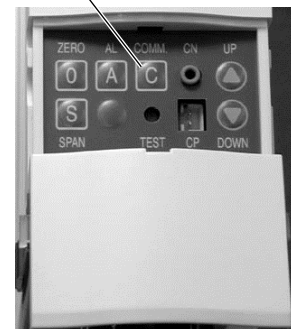

- When the same type/setting of sensor unit is installed (e.g. target gas and full scale value are the same as the previous one), go to step 9.

- 
9. “Good” is shown on the sub-display. The unit will begin a 30-second initialization mode (POWER LED flashes), then start normal operation mode (POWER LED is steady lit) with the gas concentration displayed on the LCD.

Green POWER LED  
30 sec flashing → steady lit

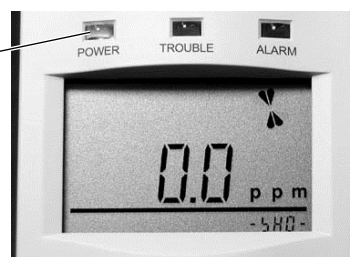

10. Check the set values.

Note: To change the set values, refer to the “PS-7 gas detector’s operation manual for administrators” (separate document).

■ To view the set values shown in the table below, press the UP/DOWN button.

Press the UP/DOWN button to cycle through the items in the sequence shown in the table.

The set value for the selected item is displayed on the sub-display (bottom right).

On sub-display	Function to set	Description/remarks	Default setting	
			Toxic: CDS-7 Combustible: CHS-7	O2: COS-7
d1 * *	Delay time 1	Delay time for 1 <sup>st</sup> stage gas alarm contact (sec)	d1 0	d1 0
d2 * *	Delay time 2	Delay time for 2 <sup>nd</sup> stage gas alarm contact (sec)	d2 0	d2 0
az	Analog output (zero)	*1	-	-
as	Analog output (span)	*1	-	-
zs *	Zero or 21vol% suppression	Suppression percentage against full scale value (in 1% increments)	zs 5	zs 2
H - H	Gas alarm mode	High-High limit	H - H	L - L
L - L		Low-Low limit		
H - L		High-Low limit		
Con *	Broken pyrolyzer wire detected	0: Detected. 1: Not detected.	Con 0	Con 0
CG * *	Calibration gas concentration	*1	CG 40	CG 84
nEt *	Comm. setting	Disabled (setting cannot be changed).	nEt 1	nEt 1
F * * *	F value	*1	-	
FL * * *	Flow rate	The current flow rate is displayed. (mL/min)	-	
P * * *	Sensor unit output	*1	-	
At *	Automatic 21vol% adjustment	0: Disabled 1: Enabled	-	At 1

\*1. For New Cosmos service engineer use.

- To view each gas alarm set value, press the AL button.

Press the AL button to cycle through the items in the sequence shown below.

A1 \* \* → A2 \* \* → (normal operation mode) → A1 \* \* → A2 \* \* →

The percentage in full-scale% is shown on the sub-display (bottom right corner).

E.g. "A1 10" represents that the 1<sup>st</sup> alarm set value is 10% of the full scale value.

The actual alarm set concentration value is shown on the LCD.

E.g. 0.10 ppm

On sub-display	Default set value		Description
A1 * *	Toxic: CDS-7	A1 10	10% of full scale value
	Combustible: CHS-7		
	O2: COS-7	A1 72	72% of full scale value
A2 * *	Toxic: CDS-7	A2 20	20% of full scale value
	Combustible: CHS-7		
	O2: COS-7	A2 76	76% of full scale value



#### 11. Check for the correct sampling gas flow rate.

Check that the flow rate icon quickly spins and the amber TROUBLE LED is off.

When the flow rate icon is quickly spinning, the specified flow rate (500mL/min) is maintained.

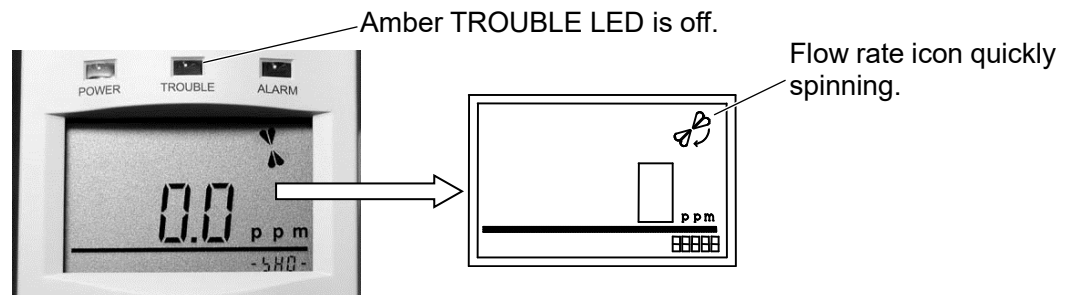

**NOTE**

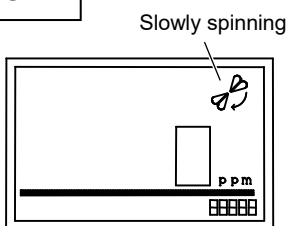

Clogging notification

The flow rate icon slowly spins when the flow rate is reduced (less than 400mL/min), indicating a possible clogged tube/filter, or excessive negative pressure, etc. Gas detection and gas-monitoring continue even when this gas notification is present.

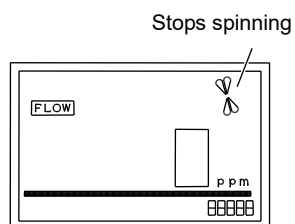

Low flow rate alarm notification

When the flow rate is too low (300mL/min or less), the flow rate icon stops and **FLOW** is shown on the LCD. The amber TROUBLE LED flashes and a trouble alarm is activated.

12. Check for the airtightness.

Disconnecting the tube from the gas inlet and fully blocking the inlet with a finger will change the flow rate icon's spinning speed from quick to slow. Keep blocking it, and check that the flow rate icon stops spinning and the amber TROUBLE LED starts flashing. (The delay time for the low rate alarm is set to 10 seconds.) The **FLOW** appears on the LCD.

If the flow rate icon stops spinning, but the amber TROUBLE LED does not flash, check that the sensor unit is installed into the main unit completely. Refer to 9-2. "Sensor Unit Installation/Replacement". Check that the latches are in the fully locked position (white lines visible).

Connect the tube back to the gas inlet. Check that the flow rate icon quickly spins.



Block gas inlet

### 13. One-touch zero/21vol% adjustment

(Zero adjustment for CDS-7, CHS-7 and 21vol% adjustment for COS-7)

Take the steps in the table below, to perform one-touch zero/21vol% adjustment once the specified period of time passes after turning on the main unit. Repeat the one-touch zero/21vol% adjustment to increase the accuracy.

Sensor unit type	Timing for 1 <sup>st</sup> adjustment	Timing for 2 <sup>nd</sup> adjustment	Steps
Toxic gas: CDS-7	30 minutes after powering-up	24 hours after powering-up	Set the maintenance switch to MNT1 or MNT2. Press the ZERO button.
Oxygen gas: COS-7 (25vol%)			Set the maintenance switch to MNT1 or MNT2. Press the SPAN button.
Combustible gas: CHS-7	One day after powering-up	7days after powering-up	Set the maintenance switch to MNT1 or MNT2. Press the ZERO button.

#### NOTE

- Depending on the environment, it may take longer than the expected 24 hour/7 day period (see above) for the base line (zero or 21vol%) to be fully stabilized.
- For COS-7 oxygen sensor (FS: 50vol%), one-touch 21vol% adjustment is not possible. However, if 21vol% adjustment is needed, refer to "PS-7 gas detector's operation manual for administrators" for the procedure (separate document).



### WARNING

Perform zero/21vol% adjustment in clean air. Inaccurate gas concentrations will be indicated if the zero/21vol% adjustment has been done in a contaminated gas atmosphere.



### CAUTION

When switching the maintenance switch from MNT1 to MNT2 or vice versa, the gas detector briefly enters the normal operation mode. If switching is done while an alarm condition exists, an alarm signal will be output. If the alarm contacts/open collector are used to operate the interlocks of the external devices, release the interlocks beforehand, as needed to prevent a possible activation of the interlocks during switching the maintenance switch.

#### Procedure

- (1) Set the maintenance switch to MNT1 or MNT2 position. Refer to 7-5. "Maintenance Mode Setting/Operation" for more information.

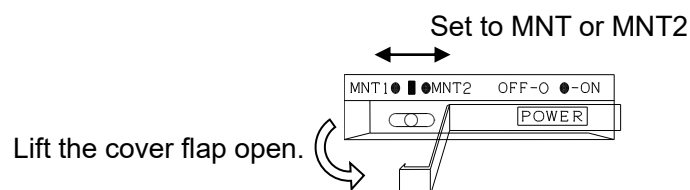

(2)

Toxic gas sensor (CDS-7)

Oxygen sensor (COS-7)

Combustible gas sensor (CHS-7)

Press the ZERO button for more than 2 seconds. The green POWER LED will flash one time, indicating the zero adjustment is completed.

Press the SPAN button for more than 4 seconds. The green POWER LED will flash one time, indicating the zero adjustment is completed.

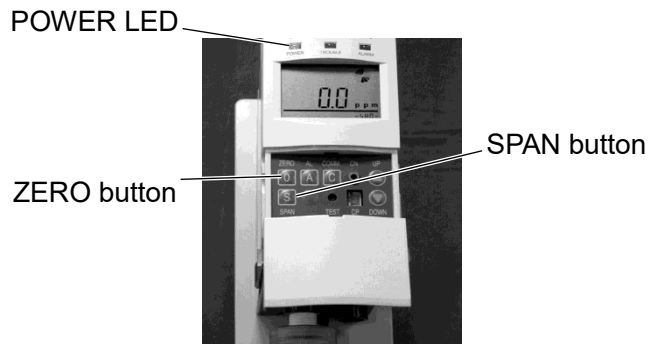

(3) Set the maintenance switch to the center position (normal operation mode).

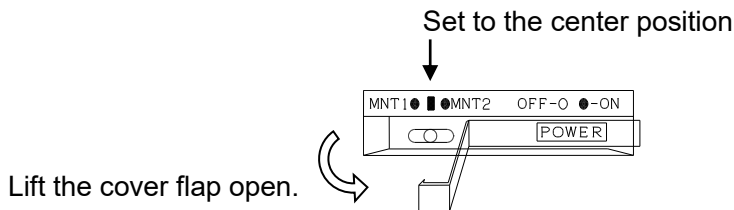

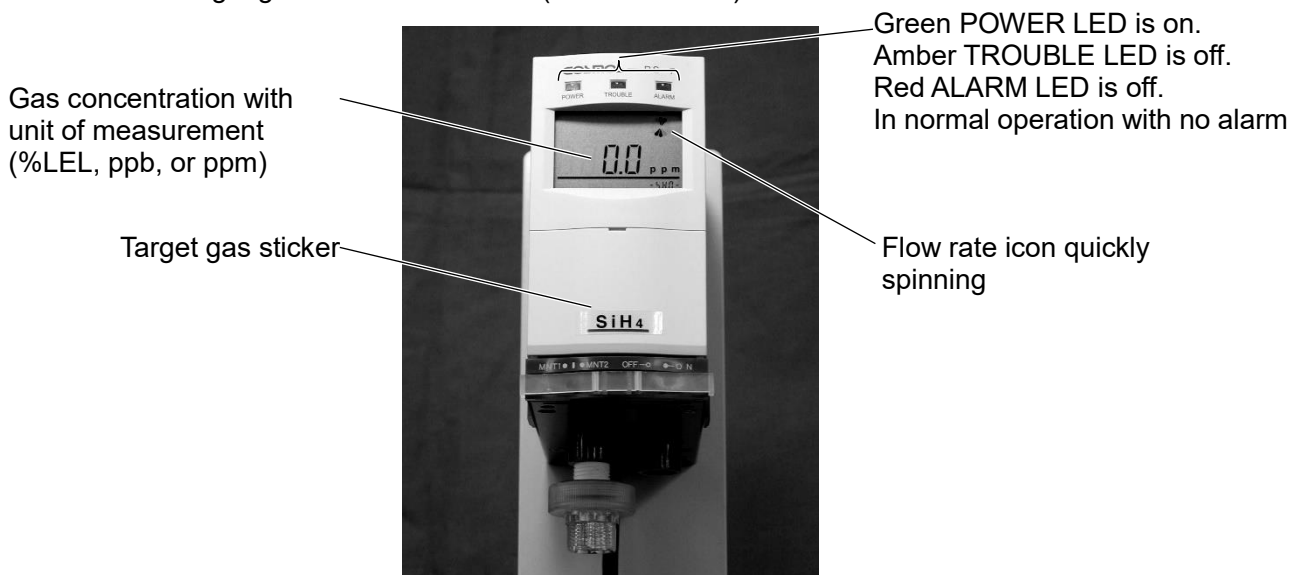

(4) Perform zero/21% adjustment again by repeating the steps (1) to (3) at the following timing:  
24 hours after powering-up for toxic gas and oxygen  
7 days after powering-p for combustible gas

14. Affix the target gas sticker to the front (visible location) of the detector.



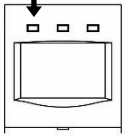
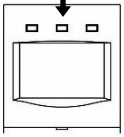
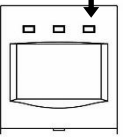
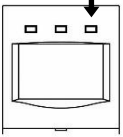
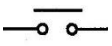
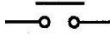

	Normal operation (gas monitoring)	Trouble alarm (internal failure)	1 <sup>st</sup> stage gas alarm	2 <sup>nd</sup> stage gas alarm
LED	Green lit 	Amber flash 	Red flash 	Red flash 
LCD		FLOW SENS. CONV.	ALARM1	ALARM1 ALARM2
Gas alarm contact (ZA1) 	OFF (open position)	OFF (open position)	ON (closed position)	ON (closed position)
Gas alarm contact (ZA2) 	OFF (open position)	OFF (open position)	OFF (open position)	ON (closed position)
Trouble alarm open collector (TA) 	ON (closed position)	OFF (open position)	ON (closed position)	ON (closed position)

## 7-2. Operation - Gas Alarm

If the gas concentration exceeds the gas alarm set value, the alarm contacts will activate after the alarm delay time, the red ALARM LED will start flashing, and **ALARM1** or **ALARM1 ALARM2** will be shown on the LCD.

Note: During the alarm delay time, **ALARM1** or **ALARM1 ALARM2** flash, the alarm contact does not activate, and the red ALARM LED does not flash.

Self-resetting: When the gas concentration falls below the gas alarm set value, the ALARM LED, **ALARM1 ALARM2** and relevant gas alarm contacts will automatically return to their normal positions/status.

The table below lists the operation of each mode in the event of a gas alarm.

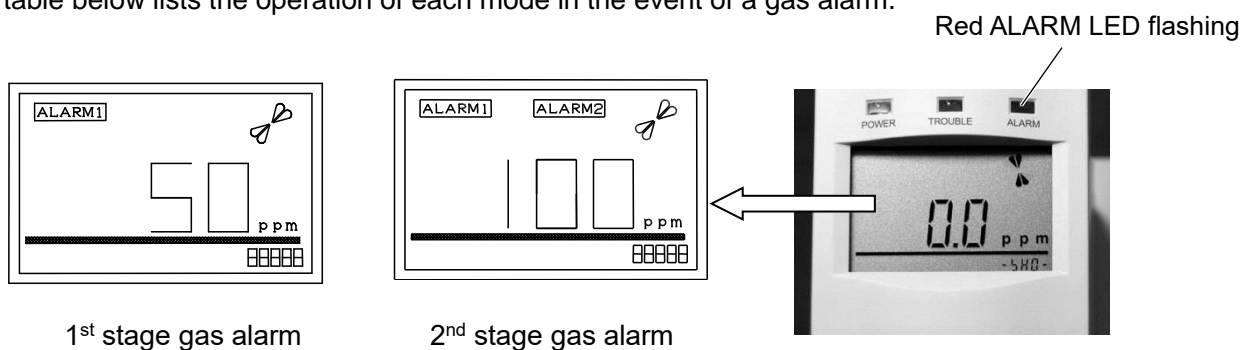

	On display	Green POWER LED	Amber TROUBLE LED	Red ALARM LED
1 <sup>st</sup> stage gas alarm	ALARM 1	On	Off	Flashing
2 <sup>nd</sup> stage gas alarm	ALARM 1 ALARM 2	On	Off	Flashing

**NOTE**

**A1 and A2 relation in each gas alarm mode**

- H - H mode (High-High limit alarm)

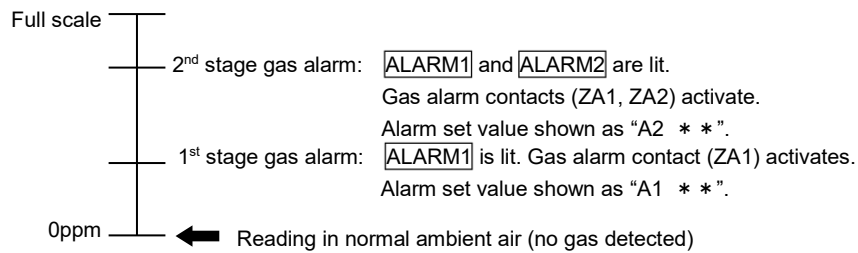

- L - L mode (Low-Low limit alarm)

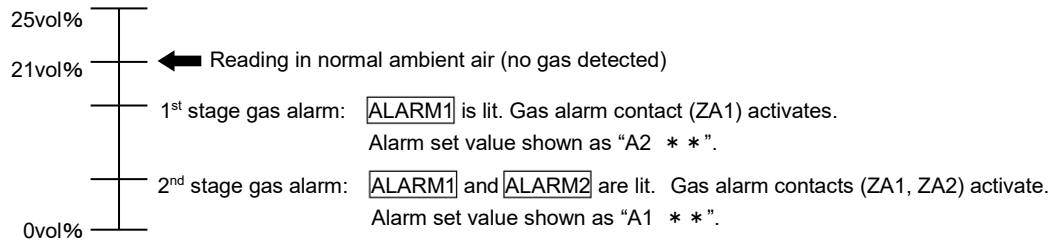

- H - L mode (High-Low limit alarm)

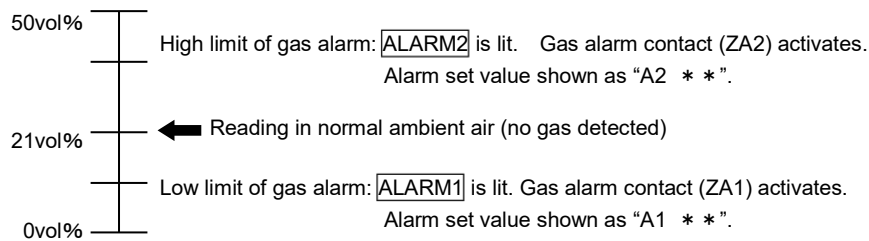

### 7-3. Operation - Trouble Alarm

This unit can detect an internal failure. When an internal failure is detected, a trouble alarm will activate (open collector is normally ON (closed position) and during a trouble alarm switches to OFF (open position). The amber TROUBLE LED will start flashing, and the analog output will fall to 0.6mA or less.

Self-resetting: When a problem is removed, the TROUBLE LED, open collector, and analog output will automatically return to their normal positions/status.

Please refer to 10. "Troubleshooting", as well.

Internal failures include:

(1) Low flow rate

When a minimum flow rate is not present, the unit determines the flow rate is too low. The **FLOW** is shown on the LCD and the spinning flow rate icon stops. The causes of a low flow rate include: clogged filter element, clogged tubing, excessive negative pressure, worn pump.

(2) Sensor fault

**SENS** appears on the LCD in the following situations:

- the sensor's zero level output is extremely low.
- a broken sensor wire is detected. This applies to combustible gas sensor (CHS-7) only.

(3) Incorrect sensor installed

The data (e.g. target gas type, full scale value) from the last installed sensor has been recorded by the gas detector. If a newly installed sensor unit does not match, the gas detector will detect that an incorrect sensor unit is installed, and display the **SENS** and " - - -" on its LCD. To use a newly installed sensor unit which does not match the previous sensor type, press the COMM. button to renew the data.

(4) Broken pyrolyzer wire (when detector uses a pyrolyzer)

If a broken wire is detected, **CONV** will appear on the LCD.

(5) No power

If the gas detector is not powered, all the LEDs will turn off and the detector will stop operation.

(6) Blown fuse

If the fuse blows, causing the unit to lose power, then all the LEDs will turn off and the detector will stop operation.

(7) Memory read error

When the internal memory cannot be read normally after powering-up, "nG" will be shown on the LCD.

 **CAUTION**

**Oxygen sensor (COS-7):** The analog output from this product falls to 0.6mA or less in the event of a trouble alarm as listed above. When the host system (e.g. control room) is set to the low limit alarm (gas alarm activates when the gas concentration falls to the alarm set value or less) and if the product's analog output falls to 0.6mA or less in under a second without a gas alarm, then it means that a trouble alarm is present. Take measure to prevent the host system from activating a gas alarm, as needed.

	Trouble (internal failure)	On display	Green POWER LED	Amber TROUBLE LED	Red ALARM LED	Remarks
(1)	Low flow rate	FLOW	On	Flashing	Off	Flow rate icon stops spinning.
(2)	Sensor fault	SENS.	On	Flashing	Off	
(3)	Incorrect sensor installed	SENS.	On	Flashing	Off	"_ _ _ _" shown for the gas concentration on the LCD.
(4)	Broken pyrolyzer wire	CONV.	On	Flashing	Off	
(5)	No power		Off	Off	Off	
(6)	Blown fuse		Off	Off	Off	
(7)	Memory read error	nG	On	Flashing	Off	Error code shown on the sub-display.

## 7-4. Operation - Test Mode

### Setting

Press the TEST switch with the test stick to enter the test mode.

Each press of the recessed TEST switch will turn on and off the test mode. The test mode will automatically end in 10 minutes.



Increase/decrease the analog output value using UP/DOWN button.

Turn on/off TEST switch with test stick.

### Operation

“TEST” will be shown on the LCD.

While in test mode, it is possible to change the analog output (4-20mA) to a desired value in 0.16mA increments (1% of the full scale value). Increase or decrease the analog output value by pressing the UP or DOWN button.

### CAUTION

- While in test mode (alarm test using TEST switch), the gas alarm contacts activate. If the gas alarm contacts are used to operate the interlocks of the external devices, release the interlocks beforehand, as needed to prevent a possible activation of the interlocks during the test mode, or enter the maintenance mode before entering the test mode, then release the interlocks of the external devices beforehand as needed. (Refer to 7-5. “Operation - Maintenance Mode” for more information).  
Notify those concerned before starting the gas alarm test.
- While in maintenance mode, the status information of gas/trouble alarms is sent to the host system (e.g. control room) digitally. If the gas alarm contacts/trouble alarm open collector are used to operate the interlocks of the external devices, release the interlocks beforehand, as needed to prevent a possible activation of the interlocks during the maintenance mode.

## 7-5. Operation - Maintenance Mode

### Setting

The maintenance switch has three modes, maintenance mode 1 (MNT1), maintenance mode 2 (MNT2), and normal operation mode (gas monitoring mode).

Set the maintenance switch to MNT1 or MNT2 on the base unit's front. "MNT1" or "MNT2" will be shown on the LCD. To return to the normal operation mode, set the maintenance switch to the center position.



Maintenance switch

MNT1 – normal operation – MNT2  
(center)

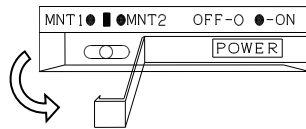

Lift the cover flap open.

### Operation

During MNT1, gas alarm contacts and trouble alarm open collector are disabled.

During MNT2, gas alarm contacts and trouble alarm open collector are disabled, and the analog output is fixed at 4.0mA (or 17.4mA for oxygen).

In either maintenance mode, the amber TROUBLE LED will flash and the detected gas concentration will be shown on the LCD.

	Gas alarm contact	Trouble alarm open collector	Analog output	Amber TROUBLE LED	On display
MNT1 (host maintenance mode <sup>*3)</sup> )	Disabled (fixed at OFF)	Disabled <sup>*1</sup> (fixed at ON)	Output corresponding to the detected gas concentration.	Flashing	Detected gas concentration value
MNT2	Disabled (fixed at OFF)	Disabled <sup>*1</sup> (fixed at ON)	Fixed at 4.0mA or 17.4mA <sup>*2</sup>	Flashing	Detected gas concentration value

### WARNING

- During normal operation (gas monitoring), ensure the maintenance switch is set to the center position. Gas alarm contacts and trouble alarm open collector do not activate during MNT1/MNT2. When the maintenance switch is set to MNT2, the analog output is fixed at 4.0mA or 17.4mA.

 **CAUTION**

- While in maintenance mode, the status information of gas/trouble alarms is sent to the host system (e.g. control room) digitally. If the gas alarm contacts/trouble alarm open collector are used to operate the interlocks of the external devices, release the interlocks beforehand, as needed to prevent a possible activation of the interlocks during the maintenance mode.
  - When switching the maintenance switch from MNT1 to MNT2 or vice versa, the gas detector briefly enters the normal operation mode. If switching is done while an alarm condition exists, an alarm signal will be output. If the alarm contacts/open collector are used to operate the interlocks of the external devices, release the interlocks beforehand, as needed to prevent a possible activation of the interlocks during switching the maintenance switch.
- \*1. Trouble alarm will activate if the main unit power switch is set to the OFF position during MNT1 or MNT2 mode. (OFF)
- \*2. The analog output may change when the main unit power switch is set to the OFF position.

**NOTE**

- Maintenance mode 1 and 2 is available with the base unit without a main unit. The base unit can produce a 4.0mA or 17.4mA analog output while in maintenance mode 2. This function is useful for loop check at startup, etc.
- \*3. It is possible to set/cancel the maintenance mode ("host maintenance mode") from the host system/device via the base unit using Modbus communication. The operation of the host maintenance mode is the same as maintenance mode 1.

## 8. Maintenance

This gas detector requires no on site gas calibration. Each sensor unit has been gas-calibrated when shipped. Replace the sensor unit with a new one every 6 months except for combustible gas sensor units (CHS-7). The CHS-7 is divided into two types, hot-wire combustible (CH) and catalytic (CS). Sensor life of CH and CS types are 5 and 3 years from the installation date respectively.

Routine checks are carried out by the user. 6-month and 3-year periodic inspections are performed by the user, New Cosmos or its authorized representative.

Record check/inspection results and save them for at least 3 years. Example of the check/inspection results is on page 39.

### Important Maintenance Notice

In order to ensure the reliability of the gas detector, it is vital to perform periodic sensor unit replacement. The replacement can be done by the user, but it is highly recommended that a maintenance contract with a local New Cosmos representative be made for the performance of periodic sensor unit replacement and inspection.

#### Inspection Contents and Frequency

Check item	Startup or relocation	Periodic Inspection		Routine check
		Every 6 months	Every 3 years	
(1) Concentration display	V	V		V
(2) Sampling gas flow rate	V	V		
(3) Airtightness	V	V		
(4) Filter element		V		
(5) Tubing	V			
(6) Sensor unit installation/replacement	V	V		
(7) Sampling unit replacement			V	
(8) Loop check and alarm test using TEST switch	V	V		



(1) Concentration display

Check that the gas concentration value is shown on the LCD and the detector is operating.

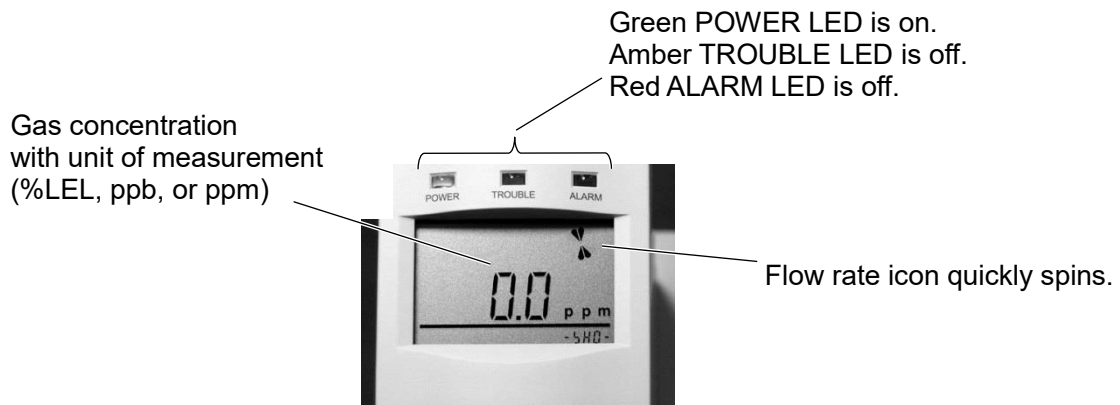

(2) Sampling gas flow rate

Check that the flow rate icon (on the right top corner of the LCD) is quickly spinning.

Refer to 7-1. 11 “Check for the correct sampling gas flow rate”

When the flow rate icon slowly spins or stops, check the filter element for contaminants. If the filter element (FE-1) is dirty, replace it with a new one. Refer to 9-1. “Filter Element Replacement” for procedure. If the flow rate icon returns to normal operation (quickly spinning), check the tubing for clogging or excessive negative pressure.

(3) Airtightness

Check the airtightness of the unit by referring to 7-1.12. “Check for the airtightness..”

(4) Filter element replacement

Check the filter element for contaminants at least once every 6 months and replace as needed. The filter element is likely to clog faster in severe environment. If the clogging notification (flow rate icon slowly spins or stops) appears on the LCD, check the filter element. Replace it with a new one, if it is dirty. Refer to 9-1. “Filter Element Replacement” for procedure.

(5) Tubing

Check that tubing has been done correctly at startup or relocation. If the tubing is incorrect, gas sampling from the target place is not possible and an appropriate flow rate cannot be maintained.

(6) Sensor unit installation/replacement

Install a new sensor unit into the gas detector at startup. Replace it with a new one every 6 months except for combustible gas sensor units (CHS-7). CHS-7 is divided into two types, hot-wire combustible (CH) and catalytic (CS). The sensor life of CH and CS types are 5 and 3 years from the installation date respectively. For procedure, refer to 9-2. “Sensor Unit Installation/Replacement”.

(7) Sampling unit replacement

Replace the sampling unit with a new one every 3 years. For procedure, refer to 9-3. "Sampling Unit Replacement".

(8) Loop check and alarm test using TEST switch

Press the TEST switch with the test stick to send a pre-set analog output to the host system. Check the output at the host system. Press the TEST switch to return the output to normal. Refer to 7-4. "Operation - Test Mode".

 **CAUTION**

- To maintain the reliability of the gas detector, perform a gas alarm test by using TEST switch, etc. at least once a month.
- While in test mode (alarm test using TEST switch), the gas alarm contacts activate. If the gas alarm contacts are used to operate the interlocks of the external devices, release the interlocks beforehand, as needed to prevent a possible activation of the interlocks during the test mode, or enter the maintenance mode before entering the test mode, then release the interlocks of the external devices beforehand as needed. (Refer to 7-5. "Operation - Maintenance Mode" for more information).  
Notify those concerned before starting the gas alarm test.

Example of the check/inspection results

No.	Model	Target gas	Full scale value
1	PS-7	CO	250 ppm
2	PS-7	SiH4	25 ppm
3			
4			
5			

No.	Location	Base value		Alarm set value		Flow rate	Alarm test using TEST switch	Airtightness	Filter element	Tubing	Replacement sensor No.	Replace sampling unit
		Before adj.	After adj.	1 <sup>st</sup> stage	2 <sup>nd</sup> stage							
1	Cabinet	0	0	50	100	■	■	■	■	■	H1021943	----
2	Device A	0	0	5	10	■	■	■	■	■	H1021944	----
3						□	□	□	□	□		
4						□	□	□	□	□		
5						□	□	□	□	□		

## 9. Consumable Parts Replacement

This product has been designed so that its consumable parts can be easily replaced by the end user. Contact New Cosmos or its authorized representative for ordering.

### 9-1. Filter Element Replacement

If the filter element (FE-1) is dirty, replace it with a new one by taking the following steps.

1. Loosen the nut of the filter unit (MF-50) and pull to separate the filter unit's top from the inlet.

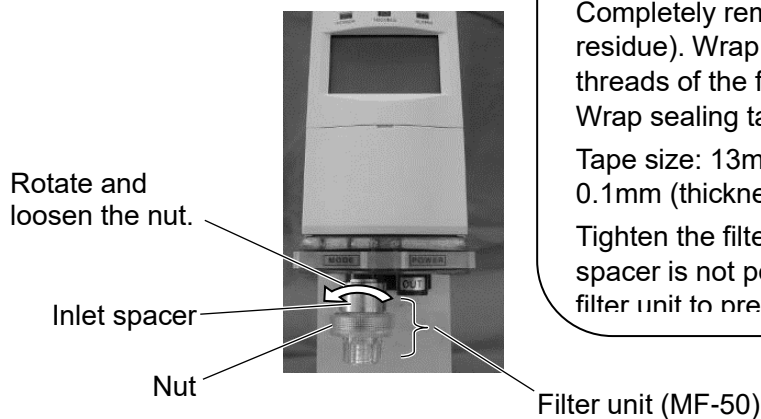

Tips when removing/reinstalling the entire filter unit from/into the gas inlet:

Completely remove old sealing tape (no residue). Wrap new sealing tape around the threads of the filter unit (approx. 2.5 wraps). Wrap sealing tape tautly to prevent slack.

Tape size: 13mm (width) x  $100 \pm 5$ mm (length) x 0.1mm (thickness)

Tighten the filter unit so that movement of the spacer is not possible. Do not over tighten the filter unit to prevent broken inlet

2. Replace the filter element with a new one.

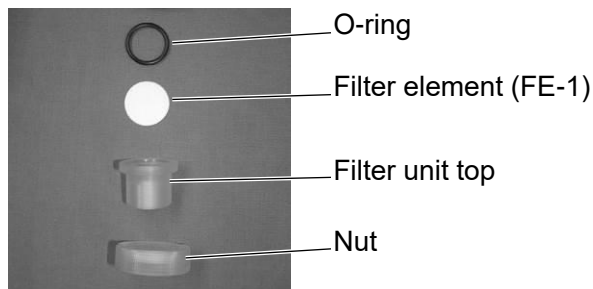

3. Install the filter unit top to the inlet. Rotate and tighten the nut to secure the tube. Ensure O-ring is correctly seated.

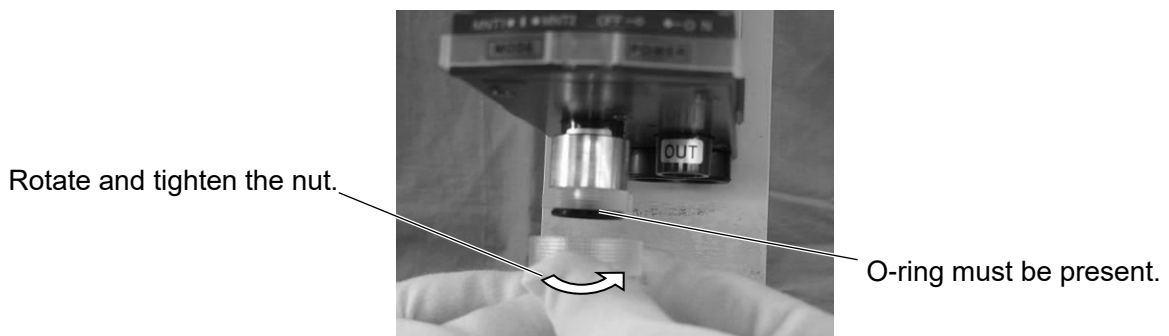

## 9-2. Sensor Unit Installation/Replacement



### WARNING

Check that the target gas type and full scale value are correct before using a new sensor unit. Also, check that the sensor unit expiration date has not been reached.

Note: The expiration year/month is not indicated on combustible gas sensor (CHS-7). CHS-7 is divided into two types, hot-wire combustible (CH) and catalytic (CS). The sensor life of CH and CS types are 5 and 3 years from the installation date respectively.



### CAUTION

- Sensor unit replacement should be performed every 6 months. Replace the expired sensor unit with a new one (except for combustible gas sensors (CHS-7)).
- The expiration year/month is written on each sensor unit's individual package. Replace the old one with a new one before the expiration date.
- Turn off the gas detector prior to sensor unit replacement. Setting the main unit power switch to the OFF position will turn off the trouble alarm output (open collector). If the trouble alarm output is used to operate the interlocks of the external devices, release the interlocks beforehand, as needed, to prevent a possible activation of the interlocks during replacement.

1. Set the main unit power switch to the OFF position.

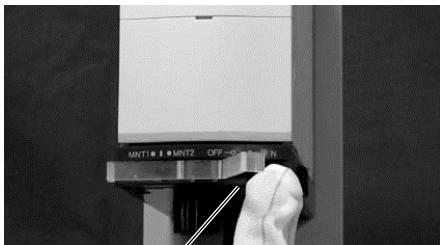

Main unit power switch

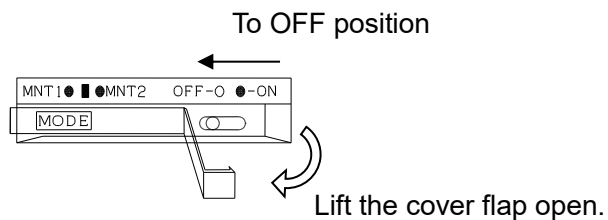

2. Pull forward the latches on both sides of the base unit and lift the main unit to remove it from the base unit.



- (2) Lift up the main unit.

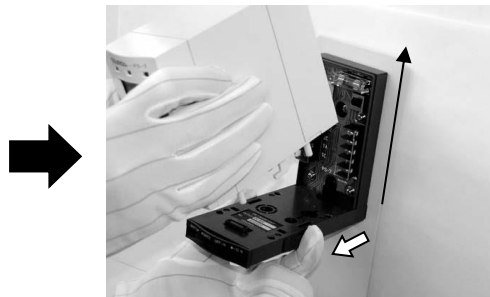

- (1) Pull forward the latches on both sides.

- 
3. Press the top of the rear cover with thumb and tip the rear cover back to separate the rear cover from the main unit.

Press here then pull back the rear cover.

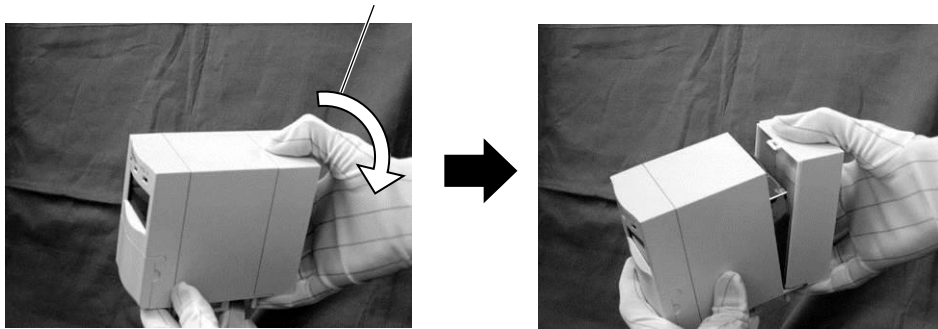

- 
4. Insert a finger between the main unit and the sensor unit so that the sensor unit tilts forward slightly. Hold the sensor unit by its sides, then pull it out of the main unit.

Insert a finger so that the sensor unit will tilt forward.

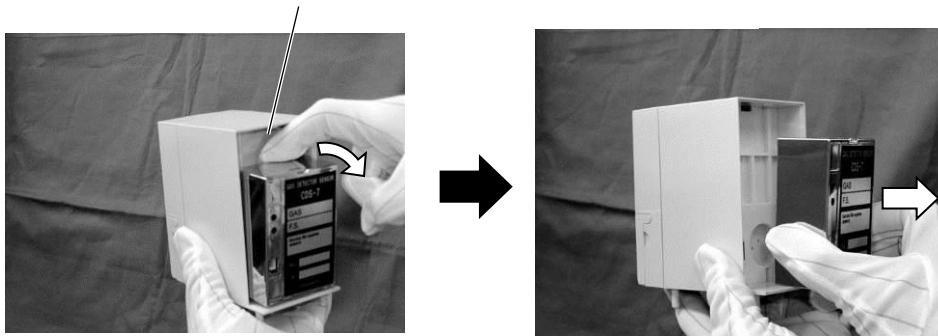

- 
5. Insert a new sensor unit. Install the rear cover.

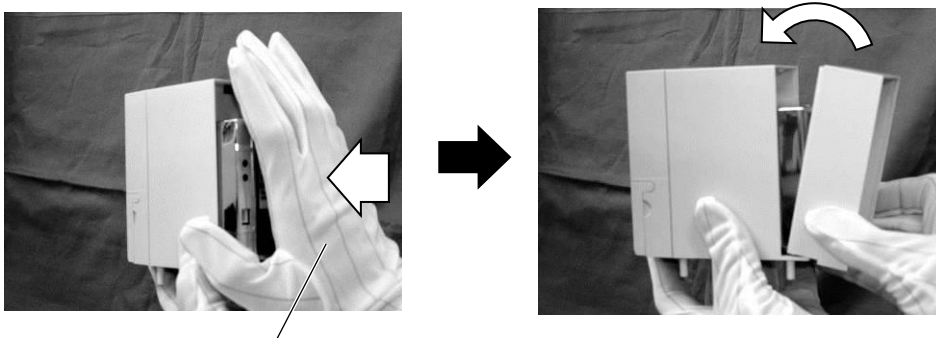

Push with palm to insert the sensor unit completely.



## WARNING

If the sensor unit is not completely inserted, an airtight seal will not be created, and correct gas detection will not be possible.

- 
6. Pull forward and hold the latches at both sides and connect the main unit by sliding it onto the rails of the base unit.

(2) Align with the rail and slide on.



(1) Pull forward and hold the latches at both sides.

- 
7. Push the base unit's latches back into place so that the white lines are visible, indicating the latches have been locked.

Push the latch (lock position).

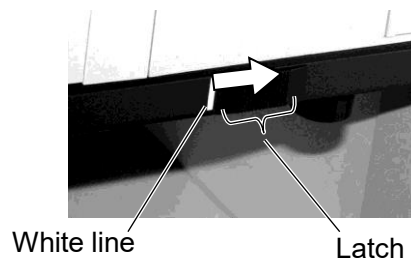

## WARNING

- Ensure that the latches are in the fully locked position (white lines visible). Normal detection is not possible if latches are not fully locked.

### NOTE

Dispose of used sensor/sampling units in accordance with applicable local laws and regulations.

### 9-3. Sampling Unit Replacement

#### CAUTION

- Turn off the gas detector prior to sampling unit replacement. Setting the main unit power switch to the OFF position will turn off the trouble alarm output (open collector). If the trouble alarm output is used to operate the interlocks of the external devices, release the interlocks beforehand, as needed, to prevent a possible activation of the interlocks during replacement.

---

1. Remove the sensor unit by taking steps 1 to 4 of 9-2. "Sensor Unit Installation/Replacement".

---

2. While pressing the front panel's bottom with both thumbs, slowly press the panel forward to remove it from the main unit.

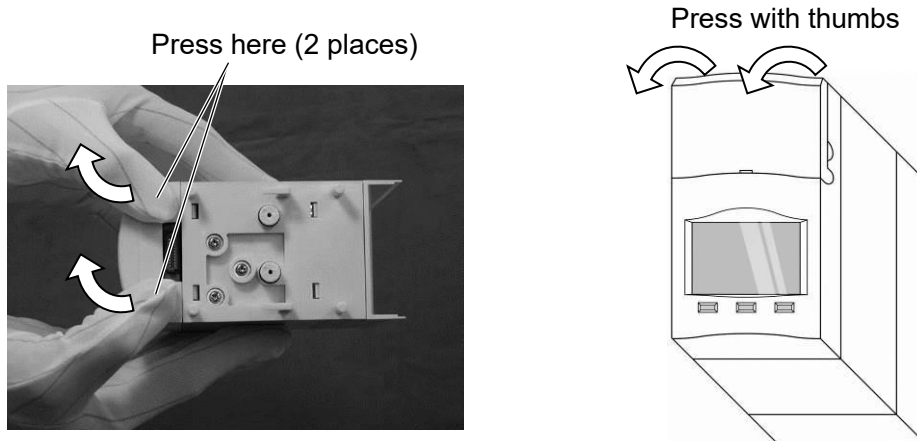

---

3. Disconnect the two connectors from the front panel.

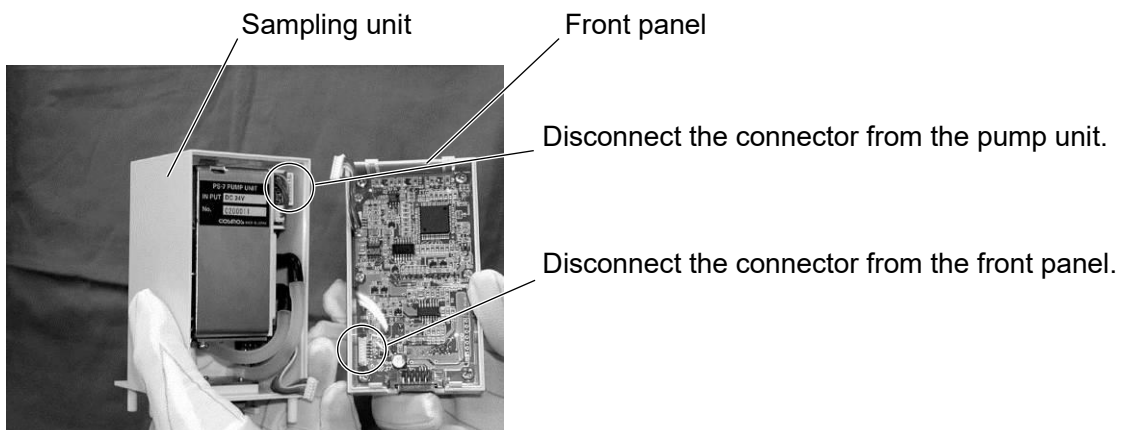

- 
4. Connect the two connectors. Mate the sampling unit and front panel. Insert the sensor unit.  
Install the rear cover.

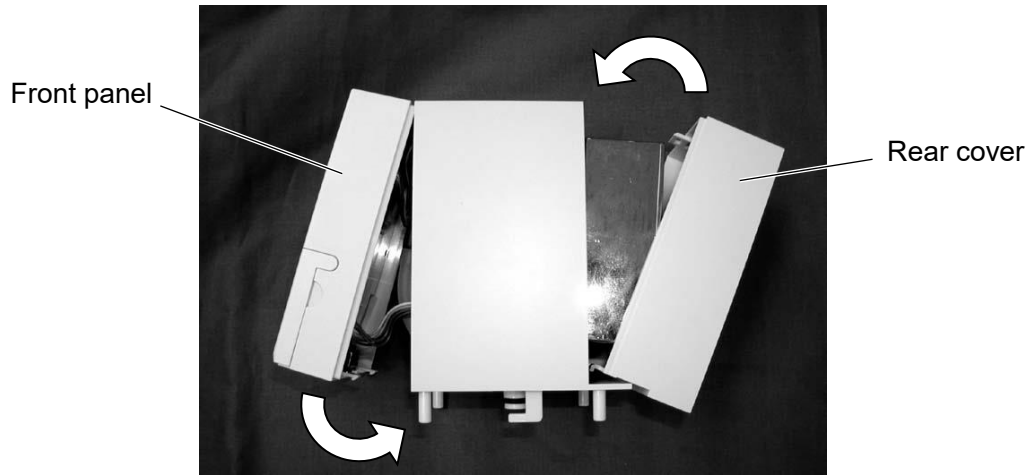

Ensure cables are not caught



## **WARNING**

If the sensor unit is not completely inserted, an airtight seal will not be created, and correct gas detection will not be possible. Take care that the cables should not be caught between the front panel and sampling unit.

- 
5. Install the main unit by referring to steps 6 and 7 of 9-2. "Sensor Unit installation/Replacement".

**NOTE**

Dispose of used sensor/sampling units in accordance with applicable local laws and regulations.



## 10. Troubleshooting

- Before requesting repair, please refer to the table below. If the detector does not return to normal operation after performing the corresponding steps in the table, or if your issue is not found in the table, consult New Cosmos or its authorized representative.
- In the event of device failure, refer to 7-3. “Operation - Trouble Alarm”, too.
- For communication problems, refer to separate “PS-7-M communication specifications guide”.

Table 3. Troubleshooting

Problem	Probable cause	Steps	Reference section
Green POWER LED does not turn on.	Base unit power switch is in OFF position.	Set the switch to ON position.	7-1.Operation Procedure
	Main unit power switch is in OFF position.	Set the switch to ON position.	7-1.Operation Procedure
	Incorrect wiring.	Check and rewire. Securely connect wires to terminals.	6-1.Wiring Procedure
	Connector to the front panel is loose.	Securely connect the connector.	9-3. Sampling Unit Replacement
	Blown fuse.	Replace the fuse. *Turn off the detector before replacement.	5-3. Base Unit
Amber TROUBLE LED flashes.	Low flow rate due to clogged filter element.	Replace the filter element.	9-1. Filter Element Replacement
	Low flow rate due to pump failure.	Replace the sampling unit.	9-3. Sampling Unit Replacement
	Low flow rate due to clogged tubing.	Remove clog from tubing.	
	Connector to the pump unit is loose.	Securely connect the connector.	9-3. Sampling Unit Replacement
	Incorrect sensor installed (data does not match the last installed sensor type)	Install the correct sensor type. To install a different sensor type, press COMM. button to renew the data.	7-1.Operation Procedure
	Sensor unit failure	Replace the sensor unit.	9-2. Sensor Unit Installation/Replacement
	Sensor unit is absent.	Install the sensor unit.	9-2. Sensor Unit Installation/Replacement
Flow sensor output is unstable immediately after powering-up.	Leave the detector on for about 30 minutes.		

Problem	Probable cause	Steps	Reference section
Gas concentration value and " _ _ _ _ " flashing alternately.	Maintenance switch is set to MNT1 or MNT2.	Set the maintenance switch to the center position (normal operation mode).	7-5. Operation - Maintenance Mode
No alarm contact output.	Maintenance switch is set to MNT1 or MNT2.	Set the maintenance switch to the center position (normal operation mode).	7-5. Operation - Maintenance Mode
	Incorrect wiring.	Check and rewire. Securely connect wires to terminals.	6-1.Wiring Procedure
Analog output is fixed at 4mA or 17.4mA	Maintenance switch is set to MNT2.	Set the maintenance switch to the center position (normal operation mode).	7-5. Operation - Maintenance Mode
Cannot change the test mode value (fixed at 0).	Test mode value is set within the zero suppression range.	1) Set the test mode value to the one greater than the zero suppression set value, or 2) Change the zero suppression set value.	1) 7-4.Operation - Test Mode 2) PS-7 gas detector's operation manual for administrators
Flow rate icon slowly spins	Low flow rate due to clogged filter element.	Replace the filter element.	9-1. Filter Element Replacement
	Low flow rate due to pump failure.	Replace the sampling unit.	9-3. Sampling Unit Replacement
	Low flow rate due to clogged tubing.	Remove clog from tubing.	
Ethernet communication error.	Poor LAN cable connection.	Connect the LAN cable.	6-1.Wiring Procedure
	Incorrect IP address.	Check that the IP address is correct.	5-4. DIP switches
	Incorrectly set DIP switch.	Set the mode change switch to ETHERNET.	5-4. DIP switches
RS-485 communication error.	Incorrect unit ID.	Check that the unit ID is correct.	5-4. DIP switches
	Incorrectly set DIP switch.	Set the mode change switch to ETHERNET.	5-4. DIP switches
Status LED is on. Status LED is off	Communication error between main unit and base unit. Loose connection of main unit.	Remove and install the main unit.	6-2. Unit Installation Procedure

# 11. Specifications

Detection principle	Electrochemical (Catalyst conversion) with/without pyrolyzer, Hot-wire semiconductor, Catalytic, or Galvanic cell
Sampling method	Extractive pump (500mL/min. auto-controlled)
Sampling tube	PTFE, Outside and inside dia.: 6mm and 4mm (or 1/4 in. and 11/64 in.) * <sup>1</sup> Piping length: < 20m * <sup>2</sup>
Target gas	As per delivery specifications
Detection range	As per delivery specifications
Gas concentration display	Four-digit LEDs on LCD display, with unit of measurement 20 segment bar graph
Alarm set value	As per delivery specifications
Alarm accuracy	<ul style="list-style-type: none"> <li>• Combustible gas: <math>\pm 25\%</math> of alarm set value under identical conditions.</li> <li>• Toxic gas: <math>\pm 30\%</math> of alarm set value under identical conditions.</li> <li>• Low oxygen: <math>\pm 1\text{vol}\%</math> of alarm set value under identical conditions.</li> </ul>
Alarm delay	<ul style="list-style-type: none"> <li>• Combustible gas: <math>\leq 30</math> seconds with a gas concentration that is 1.6 times higher than the alarm set concentration.</li> <li>• Toxic gas: <math>\leq 60</math> seconds with a gas concentration that is 1.6 times higher than the alarm set concentration.</li> <li>• Low oxygen: <math>\leq 5</math> seconds until the reading reaches 18vol% with a 10vol% concentration at <math>20^{\circ}\text{C} \pm 2^{\circ}\text{C}</math>.</li> </ul> <p>*Excludes delay time caused by piping length and communication time.</p>
Alarm indication	<ul style="list-style-type: none"> <li>• Gas alarm (2 stages) Red LED flashes. <b>ALARM1</b> and/or <b>ALARM2</b> shown on display.</li> <li>• Filter element replacement notification Flow rate icon slowly spins on display.</li> <li>• Low flow rate alarm (with 10 second delay time) Amber LED flashes. <b>FLOW</b> shown on display. Flow rate icon stops.</li> <li>• Sensor fault/incorrect sensor installed Amber LED flashes. <b>SENS.</b> shown on display.</li> <li>• Broken pyrolyzer wire Amber LED flashes. <b>CONV.</b> shown on display.</li> </ul>
External outputs	<ul style="list-style-type: none"> <li>• Digital signal: Ethernet100base-Tx(Modbus/TCP) *<sup>3</sup> Modbus/TCP (Max. number of connected units depends on the system configuration.) Max. transmission distance: 100m up to HUB Baud rate: 100Mbps</li> <li>• Digital signal: RS-485 (Modbus/RTU) *<sup>3</sup> Modbus-RTU (Max. number of connected units:32 units including master) Method: 2-wire half duplex Max. transmission distance: 1.2km up to the host device Baud rate: 9600bps * Selectable to Ethernet or RS-485 using DIP switches.</li> <li>• Gas concentration analog output signal 4-20mADC (common negative with power supply) Output accuracy: <math>\pm 0.5\%</math> of full scale * 0.6mA or less in the event of a trouble alarm * 300 <math>\Omega</math> or less including wiring resistance</li> </ul>

	<ul style="list-style-type: none"> <li>Gas alarm contacts (1<sup>st</sup> and 2<sup>nd</sup> stages) N.O. dry contact (same common), self-resetting Max. load: 30 VDC, 0.5A (resistive load)</li> <li>Trouble alarm open collector N.C. self-resetting Turns off (open position) in the event of low flow rate, sensor fault, incorrect sensor installed, or broken pyrolyzer wire, no power, or blown fuse. Max. load: 30 VDC, 30mA (resistive load)</li> </ul>								
Explosion-proof	This product is not explosion-proof equipment.								
Applicable cables for external terminals	Terminal: RJ-45 jack 8P8C Applicable cable: LAN cable, Cat. 5e or higher Target signals: Digital signal, Ethernet100base-Tx and PoE  Terminals: Terminal blocks (7-pin x1 and 6-pin x1) Screw size: M3 Applicable cable: CVV-S cable 1.25mm <sup>2</sup> (2-core shielded twisted pair cable is needed for RS-485.) Target signals: Gas concentration analog output Gas alarm contacts (1 <sup>st</sup> and 2 <sup>nd</sup> stages) Trouble alarm open collector RS-485 digital signal								
Applicable cable	Dia.8-11mm x 2 pcs								
Operating conditions	Temperature: 0°C to 40°C (No sudden temperature change) Humidity: 30 to 85%RH (No condensation)								
Approvals	EMC:2014/30/EU/SI 2016 No.1091 <sup>*5</sup> RoHS:2011/65/EU+(EU)2015/863/SI 2012 No.3032								
Power supply	24 VDC ±10% or Power over Internet (PoE) IEEE 802.3af/ANSI X3.263								
Power consumption <sup>*4</sup>	Combination	CDS-7		COS-7		CHS-7		CDS-7 +CDP-7	
		Typ.	Max.	Typ.	Max.	Typ.	Max.	Typ.	Max.
	24 VDC, gas concentration analog output used	2.3 W	4.7 W	2.8 W	4.7 W	3.0 W	5.7 W	4.8 W	8.0 W
	24 VDC, Ethernet, gas concentration analog output not used	2.4 W	4.1 W	2.9 W	4.1 W	3.0 W	5.0 W	4.9 W	7.3 W
	24 VDC RS-485 (terminal) , gas concentration analog output not used	2.7 W	4.6 W	3.2 W	4.6 W	3.4 W	5.5 W	5.2 W	7.8 W
PoE, Ethernet, gas concentration analog output not used	2.8 W	4.4 W	3.5 W	4.4 W	3.7 W	5.4 W	5.7 W	8.3 W	
Dimensions	W62mm×H142mm×D157mm (excluding protrusions, without pyrolyzer) W62mm×H172mm×D157mm (excluding protrusions, with pyrolyzer)								
Mass	Approx.1.2kg (without pyrolyzer) Approx.1.3kg (with pyrolyzer)								
Mounting method	Wall mounting								

\*1. Teflon recommended. For adsorbable gas, consult New Cosmos or its authorized representative for the

recommended material. Specify 1/4 in. 11/64 in. outside and inside diameter during order placement if the standard 6mm and 4mm outside and inside diameter tubing will not be used.

- \*2. For adsorbable gas (e.g. HF, F2, HCl, Cl2, NH3), use of less than 5m length piping is recommended. When using this product in a place exposed to dust, the piping may need to be shorter than recommended and periodically replaced.
- \*3. Refer to "PS-7-M communication specifications guide" (separate document) for the PS-7-M function command table and Modbus register map.
- \*4. More power is consumed when both analog output and digital signals are used.
- \* The above specifications are subject to change without notice.
- \* If your specifications are nonstandard, refer to the delivery specifications.
- \*5. RS-485 communication function is outside the scope of the CE marking.

## 12. Warranty

The warranty period is one (1) year from the date of purchase.

You are entitled to the limited warranty, if the product malfunctions due to a manufacturing defect during normal use in accordance with the instruction manual, specifications and labels.

### 1. Warranty Scope

If the product fails or is found to be damaged due to a manufacturing defect during the warranty period, and used in accordance with the instruction manual and specifications, we will provide a free replacement and repair service. This warranty covers the New Cosmos product/parts only and not third party product/parts.

### 2. Warranty Exclusions

The following will be repaired at the cost of customer even during the warranty period.

- (1) Failures and damages incurred by incorrect use, deliberate acts or negligence of the user.
- (2) Failures and damages caused by disaster, earthquake, storm and flood, lightning, extreme climate, abnormal power supply voltage, excessive electromagnetic interferences, or other acts of God.
- (3) Failures and damages resulting from repair and/or modification by non-New Cosmos certified technicians.
- (4) Consumables and failures and damages resulting from improper consumable replacement.
- (5) Other failures and damages not attributable to the manufacturer.

## 13. Service Life of Detector

The service life of this product is 10 years. The unit can operate for up to 10 years with a standard installation and used in accordance with the instruction manual. When the service life has expired, replacement is needed for continued reliable performance.

## 14. Disposal of Detector/Sensor/Sampling

Dispose of used sensor units/sampling units/gas detectors in accordance with applicable local laws and regulations.

## 15. Detection Principle

### 15-1. Electrochemical (Catalyst conversion) Sensor (CDS-7)

This sensor consists of three electrodes and an electrolyte, and the method adopted here is to produce electrolytic oxidation with a potentiostat circuit while keeping the working electrode at a constant potential against the reference electrode. Measuring the current generated here allows determining the concentration of the gas (e.g. H<sub>2</sub>S, CO).

The electrolytic reaction of H<sub>2</sub>S is as follows:

Working electrode:  $\text{H}_2\text{S} + 4\text{H}_2\text{O} \rightarrow \text{H}_2\text{SO}_4 + 8\text{H}^+ + 8\text{e}^-$

Counter electrode:  $2\text{O}_2 + 8\text{H}^+ + 8\text{e}^- \rightarrow 4\text{H}_2\text{O}$

### 15-2. Hot-wire Semiconductor Sensor (CHS-7-CH)

A small amount of metal oxide semiconductor is deposited on a platinum coil, then the platinum coil is heated to a high temperature. When combustible gases react with oxygen absorbed on the surface of the semiconductor, free electrons increase in the semiconductor. As a result, the resistance of the semiconductor decreases. This resistance change is read as differential voltage using a bridge circuit for gas detection purpose. This type of sensor is very sensitive and thus suitable for low concentration gas detection.

### 15-3. Catalytic Sensor (CHS-7-CS)

Catalytic combustion occurs on the catalytic layer applied on a platinum coil even if the gas concentration is well below the lower flammable limit (LFL). This causes a rise in temperature of the platinum coil and increases its electrical resistance. This change is read as a differential voltage using a bridge circuit. This process enables detection of combustible gases in air up to the lower explosive limit (LEL).

### 15-4. Galvanic Cell Sensor for Oxygen detection (COS-7)

The sensor consists of two electrodes, a membrane and an electrolyte.

The electrodes are two different metals, noble metal (Pt, Ag) and base metal (Pb). The noble metal electrode has contact with air via a Teflon membrane. Connecting load resistance to both electrodes generates a potential difference, which promotes the following reactions:

Noble metal electrode:  $\text{O}_2 + 2\text{H}_2\text{O} + 4\text{e}^- \rightarrow 4\text{OH}^-$

Base metal electrode:  $2\text{Pb} \rightarrow 2\text{Pb}^{2+} + 4\text{e}^-$

As a result, the current proportional to the oxygen concentration in the air flows from the noble metal electrode to the base metal electrode via the external circuit. Since the electromotive force changes depending on the temperature, a thermistor is added to compensate for the ambient temperature variations.

## 16. Glossary

Term	Definition
Gas detector	Device used to detect the presence of a target gas and to give its concentration in the form of an electrical signal.
Flameproof enclosure (explosion-proof enclosure)	Enclosure in which the parts which can ignite an explosive atmosphere are placed. This enclosure can withstand the pressure created during an internal explosion of an explosive mixture, and prevent the ignition of an explosive atmosphere outside the enclosure.
Target gas	Specific gas to be detected, concentration displayed, and used to trigger alarms.
Alarm set value	A gas concentration value that is set on a gas detector for alarm activation.
Detection range	A range of target gas concentrations that can be displayed and trigger alarms.
Maintenance and inspection	Tasks performed to ensure that equipment operates normally and correctly.
Alarm delay	The length of time a gas detector takes to activate an alarm after it is exposed to a target gas concentration higher than the alarm set value or to some other specified conditions.
Calibration gas ( test gas)	Gas specifically prepared to calibrate/adjust the gas detection and alarm system.
Hazardous area	An area in which an explosive atmosphere is present, or may be expected to be present, in quantities such as to require special precautions for the construction, installation and use of electrical apparatus.
Non-hazardous area	An area in which an explosive atmosphere is not expected to be present in quantities such as to require special precautions for the construction, installation and use of electrical apparatus.
Explosive atmosphere	Mixture of air and flammable substances in the form of dust or vapor which are within their explosive limits.
LEL (or LFL)	Lower Explosive Limit (or Lower Flammable Level). Lowest concentration (percentage) of a gas or vapor in air capable of producing a flash fire, or explosion in the presence of an ignition source like arc, flame or heat.
%LEL	Concentrations of combustible gas given in terms of percent of the lower explosion limit.
vol%	Gas concentrations given in terms of percent of cubic volume.
ppm	Gas concentrations given in terms of millionth part of cubic volume.

### Revision History

Document No.	Date	Revision
GAE-138-00	Feb 2019	(Initial issue)
GAE-138-01	Oct 2021	01
GAE-138-02	September 2022	02

Additional copies of this instruction manual may be purchased.  
Contact New Cosmos or its authorized representative for ordering.

**Authorized representative:**

**Manufacturer:**

NEW COSMOS ELECTRIC CO., LTD.

2-5-4 Mitsuya-naka, Yodogawa-ku  
Osaka 532-0036, Japan

URL: <http://www.new-cosmos.co.jp>



**NEW COSMOS ELECTRIC CO., LTD.**